



Public Works
LOS ANGELES COUNTY



Traffic Signal Plan Drafting Guide

Version 4.0

November 2018

TABLE OF CONTENTS

Page

Introduction	1
--------------------	---

1.0 DRAFTING PRACTICES

1.1	Line Styles and Lettering Types.....	1
1.2	Symbols	2
1.3	Dimensions and Leader Lines.....	2
1.4	Sample Plan Sheet.	3

2.0 PLAN LAYOUT

2.1	Base Plan.....	4
2.1.1	Plan Sheet.....	4
2.1.2	Scale.	4
2.1.3	North Arrow.	4
2.1.4	Intersection Orientation.	5
2.1.5	Title Block.....	5
2.1.6	Signature Block.	6
2.1.7	City Signature Block.....	6
2.1.8	State Signature Block.....	6
2.1.9	Extraordinary Maintenance/Force Account Revision Blocks.	7
2.1.10	Engineer's Stamp.....	7
2.1.11	Plan Revision Block.	7
2.1.12	Jurisdictional Percentages.	7
2.1.13	Thomas Guide Map Page.	8
2.1.14	Traffic Signal (T.S.) Revision Number.....	8
2.1.15	Phase Diagrams.....	8
2.1.16	Signal Operational Notes.	9
2.1.17	Pole Schedule.....	9
2.1.18	Pole Location Detail	10
2.1.19	Miscellaneous Details.	10
2.1.20	General Notes.....	11
2.1.21	Construction Notes.	11
2.2	Existing Topography.	12
2.2.1	Symbols.	12
2.2.2	Signal and Lighting Equipment.....	12
2.2.3	Conduit and Pull Boxes.....	13
2.2.4	Signing, Striping, and Markings.....	13
2.2.5	Surface and Near Surface Structures.	13
2.2.6	Underground and Overhead Utilities.	13
2.2.7	Sidewalks and Driveways	14
2.2.8	Crosswalks.....	14

2.2.9	Trees.....	14
2.2.10	Signal Service.	14
2.2.11	Right-of-Way (R/W) Lines and Jurisdictional Boundary Lines.....	14

3.0 FIELD CHECK

3.1	Roadway Parameters.....	15
3.1.1	Roadway Geometry.	15
3.1.2	Striping, Pavement and Curb Markings.....	15
3.1.3	Signs and Posted Speeds.....	15
3.2	Signal and Lighting Equipment.....	15
3.2.1	Signal Vehicle Heads.....	15
3.2.2	Pedestrian Heads.....	16
3.2.3	Standards.....	16
3.2.4	Pull-Boxes.....	16
3.2.5	Conduit.....	16
3.2.6	Pedestrian Push Buttons.....	16
3.2.7	Street Name Signs.....	16
3.2.8	Controller Cabinet and Controller Type.....	16
3.2.9	Detection.....	17
3.2.10	Street Lighting.....	17
3.3	Drainage.....	17
3.4	Utilities.....	17
3.5	Service.....	17
3.6	Miscellaneous.....	17
3.7	As-Built.....	17

4.0 RIGHT OF WAY REQUIREMENTS

4.0	Right of Way Requirements.....	18
-----	--------------------------------	----

5.0 REFERENCE MATERIAL

5.0	Reference Material.....	See Appendix
-----	-------------------------	--------------

- Appendix A – Striping and Utility Line Styles
- Appendix B – Symbols
- Appendix C – Typical General Notes
- Appendix D – Typical Construction
- Appendix E – Signature Blocks
- Appendix F – Sample Pole Schedule
- Appendix G – Photo Locations
- Appendix H – Sample Plans

The following CADD drafting standards outline the general practices that shall be used in preparing Traffic Signal Plans for Los Angeles County Public Works. The purpose of the standards is to promote uniformity in the preparation and drafting of these drawings. These standards are not intended to be a source for design considerations. Sample plans shall be utilized as a reference for description purposes and acceptable quality of plan work is illustrated by the samples. All plans must be prepared using MicroStation version V8i or higher.

1.0 DRAFTING PRACTICES

1.1 Line Styles and Lettering Types

Line Styles: Appendix A shows the recommended line styles, colors, and weights to be used.

- All existing equipment, signing, striping and markings shall be shown dashed.
- All proposed equipment, signing, striping, and markings shall be shown solid.

Lettering: Table 1 shows the recommended text format to be used for each text type.

- Use upper case lettering for all instructions to the contractor.
- Information or notes not pertaining to work by contractor shall be in lower case lettering.
- Lettering shall be oriented on the plan in such a manner to be legible from the lower right corner.
- Line spacing should be at least half of the height of the text that is being inserted, unless otherwise noted.

Table-1

TYPE OF TEXT	HEIGHT	WIDTH	FONT	SLANT	COLOR	WEIGHT	LEVEL
General Notes	0.1	0.1	Arial-151	0	2	2	55
Construction Notes	0.1	0.1	Arial-151	0	2	2	55
Street Names	0.25	0.25	Arial-151	0	6	4	11
Call Outs	0.1	0.175	Arial-151	0	2	2	55
City Boundaries	0.175	0.175	Arial-151	20	4	3	10

NOTE: All height and width values are given as a scale factor. Multiply the value by the scale to compute actual height.

1.2 Symbols

Appendix B shows the recommended standard symbols to be used.

- All existing signal equipment shall be shown as a thin, (weight = 1), dashed line.
- All proposed signal equipment shall be shown as a thicker, (weight = 3), solid line.

1.3 Dimensions and Leader Lines

Dimensions: Straight lines shall be used for dimensions and shall be referenced to fixed points (i.e., BCR's, curbs, etc.). Do not reference dimensions to any objects that can be removed or relocated. Dimensions and text shall be oriented on the plan in such a manner to be legible from the lower right corner.

Table-2 shows the typical items that require dimensions and how they should be dimensioned:

Table-2

Item	Dimension Reference Point
Street Widths	Street Centerlines / Curb Face / Edge of Pavement
R/W Widths	Street Centerlines / Curb Face / Edge of Pavement
Loop Locations	BCR / ECR / Curb Face / Edge of Pavement
*Equipment Locations	BCR / ECR / Curb Face / Edge of Pavement
Lane Lines	Curb Face / Edge of Pavement / Street Center Line / Along Lane Lines
Curb Markings (i.e. Red Curb)	BCR / ECR, Along Curb

*Typically, pole locations are indicated on the pole schedule.

Leader Lines: Leader Lines shall be used to reference a notation or construction note to an object or item on the plan. Avoid crossing leader lines with dimension lines and other leader lines.

Curved Leader Lines: Curved leader lines can be used to call out more than one item at once. Use a straight-line bracket for notes with two or more lines.

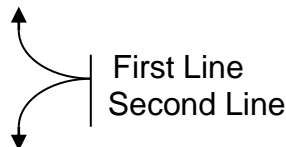

3-point Leader Lines: A 3-point leader line can be used in conjunction with a construction note call out box.

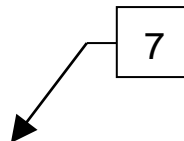

Call Out Boxes: Call out boxes shall be 6 X 6 on a 20 scale and have a number that references a Construction Note.

1.4 Sample Plan Sheet

Appendix H shows sample plans that will be used as reference in the layout of new traffic signal plans, modified/clouded traffic signal plans, signing and striping plans, and utility plans.

2.0 PLAN LAYOUT

Before a traffic signal plan is drafted, it is necessary to make a preliminary evaluation of the arrangement of the intersection. The process of plan layout is described in this section. All the traffic signal elements should be considered when preparing a plan. The sample plans provided in Appendix H show each item and their recommended locations. An electronic copy of each of the items can be obtained from the County.

2.1 Base Plan

2.1.1 Plan Sheet

All plans and traffic signal modification drawings shall be prepared on a 2 feet by 3 feet size sheet with 1" minimum margins (See Appendix H - Sample Plans).

2.1.2 Scale

All traffic signal plans shall be drawn at a scale of 1" = 20'.

All traffic signal modification drawings shall be drawn proportionally but may also be drawn at a scale of 1" = 20'.

All signing and striping plans shall be drawn at a scale of 1" = 40'.

2.1.3 North Arrow

The North arrow should be placed in the upper left-hand corner of the plan and to the right of the Signal Phase Diagram. The north arrow shall point either straight up or towards the left as shown below.

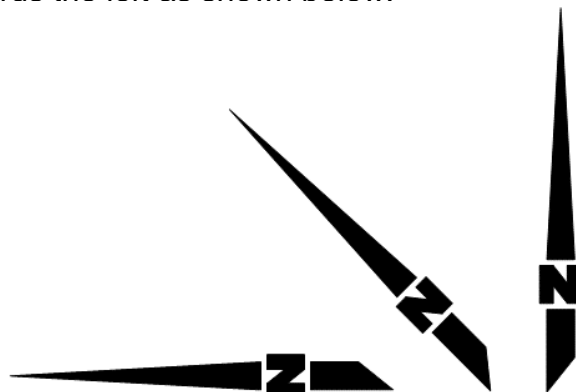

2.1.4 Intersection Orientation

The intersection should be centered on the plan sheet. Streets should be oriented on the plan in such a manner as to cause the north arrow to point up or towards the left. The major or main street should be placed horizontal on the sheet.

Show street center lines, street names, County-City boundaries, curb lines (or edge of pavement if no curb exists or is being proposed), Right-of-Way lines, BCR, ECR, and existing/proposed access ramps. Cross gutters and local depressions shall only be shown if necessary to justify proposed design, especially in placement of detector loops.

2.1.5 Title Block

The Title Block shall be placed on the bottom right corner of the plan. The Title Block should include all information as seen in Figure 2.1.A.

Figure 2.1.A

COUNTY OF LOS ANGELES DEPARTMENT OF PUBLIC WORKS TRAFFIC AND LIGHTING DIVISION			
TRAFFIC SIGNAL PLAN ARTERIAL STREET AT MINOR STREET			
I/S X OF X	SHT X OF X	SCALE: 1" = 20'	T.S. XXXX

2.1.6 Signature Block

The Signature Block shall be placed directly to the left of the Title Block as illustrated on the sample plans in Appendix H. The Signature Block should be in a format as shown in Appendix E. For plans prepared by a consultant, the consultant shall also include their own signature block on the plan.

2.1.7 City Signature Block

The City Signature Block should be placed directly below the Signature Block. The City Signature Block shall contain all the information as shown in Figure 2.1.B.

Figure 2.1.B

APPROVED: CITY OF XYZ	
BY: _____	DATE: _____

Provide one signature block for each city having jurisdiction over the intersection.

2.1.8 State Signature Block

The State Signature Block should be placed to the right of designer's name block at lower left corner. The State Signature Block should consist of all the information as seen in Figure 2.1.C.

Figure 2.1.C

CALTRANS-TRAFFIC			
REVIEWED BY	REVIEWED BY	REVIEWED BY	DATE

2.1.9 Extraordinary Maintenance/Force Account Revision Blocks

The EOM/FA signature block should be placed above the Title Block. See Appendix E, Modification to an Existing Traffic Signal Plan, *Extraordinary Maintenance* and *Force Account* revision blocks for the signature blocks that should be used.

2.1.10 Engineer’s Stamp

The Engineer’s Stamp should be placed to the left of the Signature Block as illustrated on the sample plan in Appendix H. For plans prepared by a consultant, the consultant shall use their stamp on the plan.

2.1.11 Plan Revision Block

The Plan Revision Block should be placed at the bottom left corner of the plan, at a 90-degree angle to the border of the plan as illustrated on the sample plan in Appendix H. The block should consist of all the information as seen in Figure 2.1.D.

Figure 2.1.D

REVIEWED BY	SUPERVISED BY	SPOTTED	DRAWN	#	PROJECT	CAD FILE NAME	DATE	BY	REVISIONS

2.1.12 Jurisdictional Percentages

Indicates the percentage of the City’s jurisdiction at an intersection.

Jurisdictional percentages shall be placed above the Signature Block as illustrated on the sample plans in Appendix H.

2.1.13 Thomas Guide Map Page

Thomas Guide page number and coordinates should be placed at the lower left margin as illustrated on the sample plans in Appendix H.

2.1.14 Traffic Signal (T.S.) Revision Number

All existing traffic signal plans that are modified, revised, or clouded shall show the sequential numerical revision number (R-x) after the T.S. number on the Title Block located on the lower right-hand corner of the plan. See example in Appendix H – Sample Clouding T.S. Plan.

2.1.15 Phase Diagrams

Phase diagrams shall indicate the existing and proposed operation of the traffic signal at the intersection.

The Phase Diagrams should be drawn as shown in figure 2.1.E. The phase diagrams should be placed at the upper left-hand corner of the plan and shall be labeled as either Existing or Proposed. If a change in operation is recommended, both the existing and proposed phase diagrams should be shown. Vehicle movements shall be indicated with a solid line with an arrow showing the direction of the movement. Pedestrian movements shall be indicated with a dashed line.

Figure 2.1.E

EXISTING SIGNAL PHASE DIAGRAM

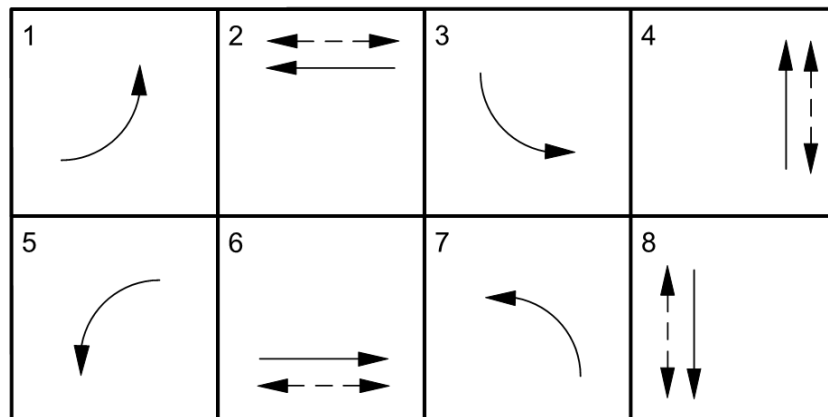

2.1.16 Signal Operational Notes

These notes shall describe the recommended operation of the traffic signal.

Signal Operational notes should be placed directly beneath the Existing and/or Proposed Signal Phase Diagram as illustrated on the sample plan in Appendix H.

2.1.17 Pole Schedule

The Pole Schedule shows the inventory of the poles and pole equipment being used at an intersection. Each item shall be labeled whether it is Existing (E), New (N), or Relocated (R). When there is a majority of one type of equipment (Existing, New, or Relocated), the following can be written below the pole schedule instead of labeling each item: "All equipment is *existing* unless otherwise noted."

All abbreviations or symbols used in the pole schedule shall be identified below the pole schedule.

The Pole Schedule shall be placed at the lower-left of the plan as illustrated in the sample plan in Appendix H. The pole schedule should be in the format as shown in Figure 2.1.F. Refer to Appendix F for a complete Sample Pole Schedule.

Figure 2.1.F

POLE SCHEDULE																	
POLE			SIGNAL M.A. LENGTH	SIGNAL MOUNTING			LUMINAIRE		PED PUSH BUTTON		STREET NAME SIGN		POLE LOCATION				
NO.	TYPE	SPEC YEAR		M.A.	POLE	PED	M.A. LENGTH	H.P.S. WATTS	NO.	PHASE	TYPE	LEGEND	A	B	C	D	E
①	----	----	----	----	----	----	----	----	----	----	----	----	----	----	----	----	
②	----	----	----	----	----	----	----	----	----	----	----	----	----	----	----	----	
③	----	----	----	----	----	----	----	----	----	----	----	----	----	----	----	----	
④	----	----	----	----	----	----	----	----	----	----	----	----	----	----	----	----	
⑤	----	----	----	----	----	----	----	----	----	----	----	----	----	----	----	----	
⑥	----	----	----	----	----	----	----	----	----	----	----	----	----	----	----	----	
⑦	----	----	----	----	----	----	----	----	----	----	----	----	----	----	----	----	
⑧	----	----	----	----	----	----	----	----	----	----	----	----	----	----	----	----	

2.1.18 Pole Location Detail

This detail supplements the pole schedule. The Pole Location Detail should be placed next to the Pole Schedule as illustrated on the sample plan in Appendix H. The pole location detail is shown in figure 2.1.G.

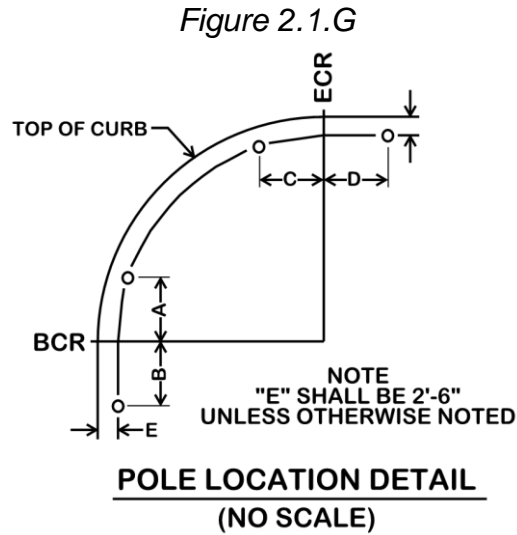

2.1.19 Miscellaneous Details

Other miscellaneous details such as median nose reconstruction (Figure 2.1.H), pavement restoration adjacent to curb ramps (Figure 2.1.I), vehicle head configurations, and special sign details should be placed at the upper-left side of the plan.

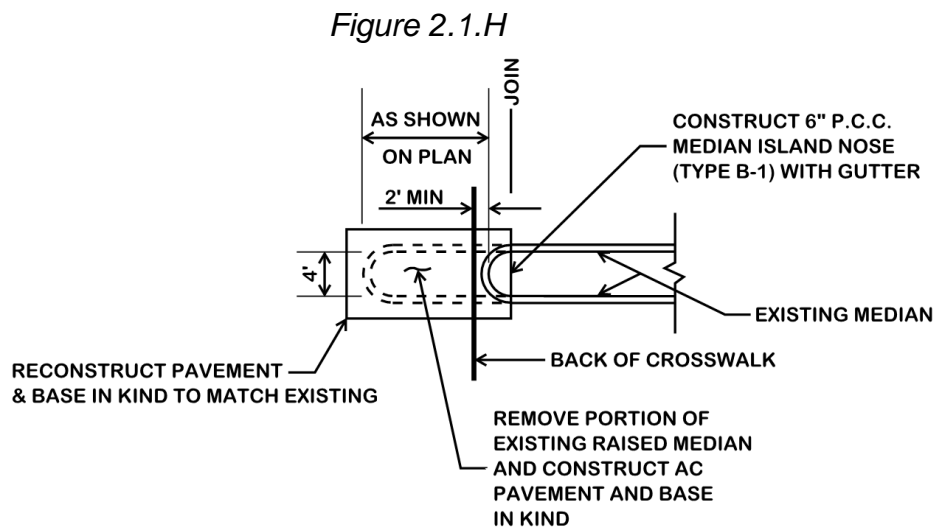

DETAIL " "
(NO SCALE)

Figure 2.1.1

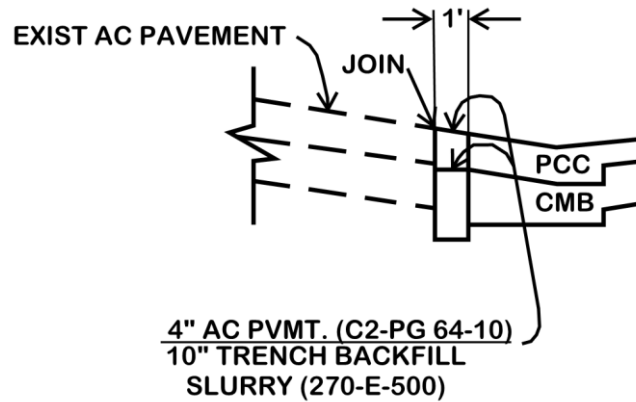

DETAIL " "
(NO SCALE)

2.1.20 General Notes

General Notes should be placed at the upper right-hand side of the plan as illustrated on the sample plans in Appendix H.

General Notes shall be used to describe who will perform the necessary work indicated in the Construction Notes. Also, it will give specific instructions on how the work shall be done and what equipment is to be used.

Appendix C shows typical General Notes used by the County. These notes can be modified, or additional ones created, to reflect the work to be performed.

2.1.21 Construction Notes

Construction Notes should be placed at the bottom right-hand side of the plan as illustrated on the sample plan in Appendix H.

Construction Notes shall be used to describe specific work to be performed. All Construction Notes shall have a number in a call out box assigned to the note and listed in numeric, sequential order under the Construction Notes heading.

Appendix D shows typical Construction Notes used by the County. These notes can be modified, or additional ones created, to reflect the work to be performed.

2.2 Existing Topography

2.2.1 Symbols

Appendix B shows the typical symbols used by the County.

2.2.2 Signal and Lighting Equipment

Show all signal and lighting equipment. All 8" lenses, which are not mounted on the signal mast arm, should be labeled on the plan. All arrow indications, i.e., 3-12" (RA, YA, GA), 4-12" (R, Y, G, GA) or 5-12" (R, Y, G, YA, GA), should be labeled on the plan with the corresponding detail. (See Figure 2.2.A)

Figure 2.2.A

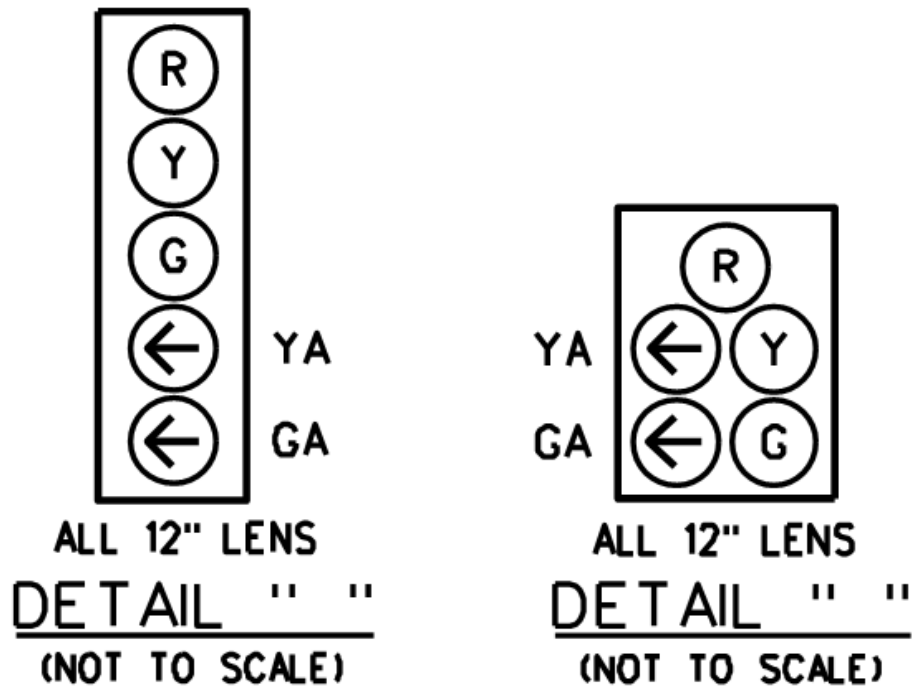

2.2.3 Conduit and Pull Boxes

All proposed and existing conduit sizes, pull-boxes, and street lighting pull-boxes (slpb) shall be labeled.

Conductor Schedules are not required for intersections in County jurisdiction, however, other agencies may require them at shared intersections or 100% City intersections (this may depend on who maintains the intersection). If required, the agency's guidelines for the conductor schedule may need to be followed.

2.2.4 Signing, Striping, and Markings

All existing and proposed signing, striping, and pavement and curb markings shall be shown and labeled in conformance with County legend and abbreviations. See Appendix A for Striping Line Styles.

2.2.5 Surface and Near Surface Structures

Show all surface and near-surface structures that may affect the installation or modification of signal and/or lighting equipment. These include box culverts, catch basins, catch basin connector (outlet drain) pipes, water valves, manholes, Edison vaults, telephone vaults, pull-boxes, etc. The vaults should be shown with the full subsurface dimensions with surface access shown either square or round. Show storm drain mains or laterals if they are in the area of any proposed conduits, including those crossing the roadway.

2.2.6 Underground and Overhead Utilities

Show and label all underground utilities, (i.e. gasoline, oil, medium and high-pressure gas lines), Edison underground and overhead lines, telephone ducts and cables, cable company conduits, sewer lines, and/or any utilities that may affect the location of the signal equipment, including traffic signal and streetlighting conduits or cables.

All utilities shall be called out as to size, material, type, utility owner and offset, and located on plan in their proper place with respect to centerline, curb line, or property line. High pressure gas lines, and the kV rating for high voltage electrical lines shall be called out. Utilities which are

abandoned shall be called out, and any single utility wider than 2 feet shall be shown using two lines separated to indicate the outside extents of the facility. Projects that occur within Caltrans' jurisdiction or that use federal (FHWA) funding shall identify and call out utilities per Caltrans' requirements for such.

For intersections with extensive utilities, a separate utility plan may need to be prepared as illustrated on the sample utility plans in Appendix H.

See Appendix A for sample Utility Line Styles.

2.2.7 Sidewalks and Driveways

Show all sidewalks and driveways near curb returns, signal standards, and loop detectors.

2.2.8 Crosswalks

Label all yellow and thermo-plastic crosswalks.

2.2.9 Trees

Show trees if they require crown raising, or removal at locations of proposed traffic signals, to enhance the visibility of the traffic signal.

2.2.10 Signal Service

Show location of the service, the service pole or vault number, the service provider, service conduit size, and pull-box location and size.

2.2.11 Right-of-Way (R/W) Lines and Jurisdictional Boundary Lines

Show and label all R/W lines and Jurisdictional Boundary Lines on the plan. Line types shall be as indicated in Appendix A.

3.0 FIELD CHECK

A field check should be conducted prior to preparing a traffic signal plan. The following list illustrates some, but not all, of the items that should be picked up during the field check. Photos should be taken of all approaches at the locations indicated in Appendix G.

NOTE: All the items listed below should be obtained from approximately 400 feet of each approach on an arterial street and 250 feet of each approach on a minor street.

3.1 Roadway Parameters

3.1.1 Roadway Geometry

Pick up all roadway widths, curb return radii, raised pavement medians, RR tracks, curb ramps, sidewalks, bus pads, bridge decks, driveways, alleys, and pavement type (concrete or A.C.).

3.1.2 Striping, Pavement and Curb Markings

Pick up all crosswalks (including location from BCR, width and color), lane lines and lane widths, left turn pockets with length, pavement markings including arrows, RR crossings, red and yellow curbs, and “NO STOPPING ANYTIME” and “NO PARKING ANYTIME” zones.

3.1.3 Signs and Posted Speeds

Pick up the location of all warning, regulatory and guide signs; including posted speed signs on all approaches.

3.2 Signal and Lighting Equipment

3.2.1 Signal Vehicle Heads

Pick up all vehicle head types (i.e. 3-section, 5-section), hoods, size and type of lenses (i.e. PV, LED, 12” arrow or ball, etc.), and terminal compartments.

3.2.2 Pedestrian Heads

Pick up all pedestrian head types and messages displayed. Indicate countdown, audible and substandard pedestrian signals when present.

3.2.3 Standards

Pick up signal standard type and location from BCR, signal mast arm lengths, and luminaire mast arm lengths and luminaire wattage.

3.2.4 Pull-Boxes

Pick up type, size, and location.

3.2.5 Conduit

Pick up conduit size and approximate location.

3.2.6 Pedestrian Push Buttons

Pick up location, type (i.e. ADA compliant) and the phase which it serves.

3.2.7 Street Name Signs

Note whether the signs are internally illuminated or retro-reflective, and pick up street names.

3.2.8 Controller Cabinet and Controller Type

When directed by the Agency, pick up cabinet inventory which includes type of cabinet and location of cabinet, controller model, signal phasing and operation, number of ILD sensor units, number of switch packs, number of pedestrian isolation modules, type of modem, program type, interconnect type, and any other equipment located in the controller cabinet.

3.2.9 Detection

Pick up detection type, size, location, phase designation, and number of detector lead-in cables.

3.2.10 Street Lighting

Show street lighting only within 300 feet of the intersection.

3.3 Drainage

Pick up box culverts, catch basins, gutter widths, cross gutters, local depression affecting ILDs, and manholes affecting ILDs or conduit runs.

3.4 Utilities

Pick up power poles, hydrants, guy poles, guy wire anchors, valves (gas, water, etc.), meters (gas, water, etc.), utility vaults, and any hazardous overhead and underground utilities at or near the intersection.

3.5 Service

Pick up service type and location, service conduit size and length, service point (pole number or vault), pull-box (location and size) in vicinity of service point.

3.6 Miscellaneous

Pick up trees or other objects that may conflict with proposed traffic signal equipment and/or be in the line of sight of the traffic signal.

3.7 As-Built

Upon completion of the project, the original signed design plans should be revised to show all the construction changes. The revision block should be filled in to indicate the specific changes made on each sheet, and the words "As-Built" should be included in the lower right-hand corner of each sheet.

4.0 RIGHT OF WAY REQUIREMENTS

Any need for additional right of way, other than what is existing, should be determined at this point in the design of the traffic signal.











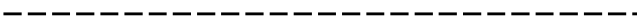

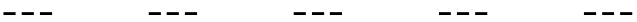

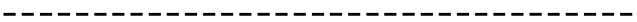





A “permit” to enter, construct, and maintain traffic signal equipment and appurtenances should be obtained from railroad companies, public utilities, County, and/or City properties and other long-term entities.

Any easement for the same purposes as a “permit” should be obtained in all cases where there is a possibility the property needed may be sold to another party. A “permit” becomes null and void with a change in ownership.

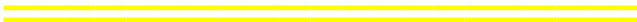
A “permit” or easement shall be obtained before a project goes to contract.

APPENDIX A

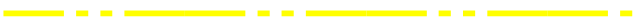
TRAFFIC AND LIGHTING LINE STYLES

		<u>LINE STYLE</u>	LEVEL	COLOR	WEIGHT
EXIST SOLID		EXSOLID	8	W	1
SOLID		SOLID	15	C	3
EXIST LANE		EXLANE	8	W	1
PROP LANE		PROPLANE	9	C	3
EXIST LEADIN		EXLEADIN	21	W	1
PROP LEADIN		LEADIN	22	C	3
EXIST CONDUIT		CONDUIT	16	M	0
PROP CONDUIT		CONDUIT	17	M	3
EXIST LANE EXTENSION		EXLNEXT	8	W	1
PROP LANE EXTENSION		LNEXT	9	C	3
EXIST LANE DROP		EXLNDROP	8	W	1
PROP LANE DROP		LANEDROP	9	C	3
EXIST LANE EXTENSION		EXLNEXTA	8	W	0
PROP LANE EXTENSION		LNEXTA	9	C	1
EXIST DOUBLE CENTER		EXDOUBLE	8	Y	1
PROP DOUBLE CENTER		PROPDBL	9	Y	3
EXIST PASSING ZONE		EXPASSZN	8	Y	1
PROP PASSING ZONE		PASSZONE	9	Y	3
CENTER LINE		CLINE	35	G	0
R / W LINE		R/W	6	B	6
CITY BOUNDARY		CITY	35	Y	4
LIGHTING DISTRICT BOUNDARY		LGTBDY	30	G	3
COMMON LIGHTING DISTRICT BOUNDARY		CLGTBDY	31	Y	1

COLOR LEGEND:

R= RED
B= BLUE

G= GREEN
W= WHITE

Y= YELLOW
M= MAGENTA





















C= CYAN
O= ORANGE

BR= BROWN
GR= GRAY

P= PURPLE
NOT TO SCALE

APPENDIX A

UTILITY LINE STYLES

<u>SUBSURFACE</u>		<u>LINE STYLE</u>	LEVEL	COLOR	WEIGHT
TELEVISION		TV	8	O	1
TELEPHONE		PHONE	14	O	1
TELECOM		TELECOM	18	O	1
FIBER OPTIC		FIBER	20	O	1
ELECTRICAL		ELECTRIC	9	R	1
STREET LIGHT		LIGHT	11	R	1
WATER		WATER	17	B	1
RECLAIMED WATER		RCWATER	17	P	1
STORM DRAIN		DRAIN	15	G	1
SEWER		SEWER	16	G	1
GASOLINE		FUEL	10	Y	1
NATURAL GAS		GAS	12	Y	1
OIL		OIL	13	Y	1
STEAM		STEAM	21	Y	1
CHEMICAL		CHEMICAL	19	Y	1
<u>OVERHEAD</u>					
TELEVISION		TV	8	O	1
TELEPHONE		PHONE	14	O	1
TELECOM		TELECOM	18	O	1
FIBER OPTIC		FIBER	20	O	1
ELECTRICAL		ELECTRIC	9	R	1

COLOR LEGEND:

R= RED
B= BLUE

G= GREEN
W= WHITE



























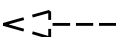

Y= YELLOW
M= MAGENTA

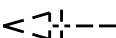
C= CYAN
O= ORANGE

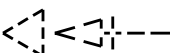
BR= BROWN
GR= GRAY

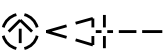
P= PURPLE
NOT TO SCALE

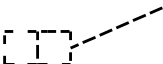
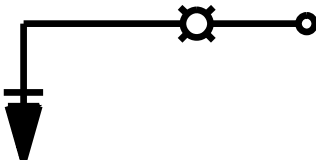
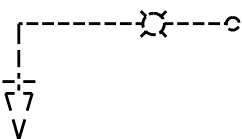
APPENDIX B

PROPOSED	EXISTING	
		SIGNAL AND LIGHTING CONDUIT
		DETECTOR AND SERVICE CONDUIT
		STREET LIGHTING CONDUIT
		LOUVERED VISOR (LEFT ANGLE SHOWN - REVERSE FOR RIGHT ANGLE)
		TRAFFIC SIGNAL PULL BOX (PB)
		STREET LIGHTING PULL BOX (SLPB)
		CONTROLLER CABINET
		UNDERGROUND SERVICE CABINET
		TRAFFIC SIGNAL POLE
		VEHICLE SIGNAL HEAD WITH NO BACK PLATE
		VEHICLE SIGNAL HEAD WITH BACK PLATE
		PROGRAMMED VISIBILITY VEHICLE HEAD (3-12" SECTIONS)
		SIGNAL VEHICLE HEAD WITH ALL 12" ARROW INDICATIONS (REVERSE DIRECTION OF ARROW FOR LEFT OR RIGHT TURNS)
		PEDESTRIAN SIGNAL HEAD
		SIGNAL AND LUMINAIRE MAST ARMS WITH VEHICLE SIGNAL HEAD, 3-12" SECTIONS WITH BACK PLATE
		MAST ARM WITH VEHICLE SIGNAL HEAD, 3-12" SECTIONS WITH BACK PLATE

LOS ANGELES COUNTY PUBLIC WORKS

SYMBOLS

SHEET 1 OF 3

APPENDIX B

PROPOSED

EXISTING

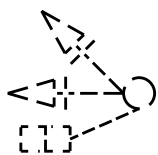
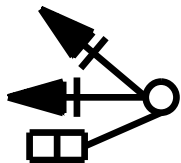

TRAFFIC SIGNAL POLE WITH VEHICLE SIGNAL AND PEDESTRIAN HEADS

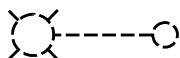

TRAFFIC SIGNAL POLE WITH LUMINAIRE MAST ARM



RETRO-REFLECTIVE MAST ARM MOUNTED SIGN



INTERNALLY ILLUMINATED MAST ARM MOUNTED SIGN



INDUCTIVE LOOP DETECTOR



BICYCLE LOOP DETECTOR



VIDEO DETECTION CAMERA



VIDEO DETECTION ZONE



WIRELESS RADIO ANTENNA



FLASHING BEACON



MANHOLE



FIRE HYDRANT

LOS ANGELES COUNTY PUBLIC WORKS

SYMBOLS

SHEET 2 OF 3

APPENDIX B

PROPOSED

EXISTING



TELEPHONE POLE



POWER POLE



STREET LIGHTING POLE



WATER METER



UTILITY VAULT



UTILITY VALVE



RAILROAD CROSSING SIGNAL

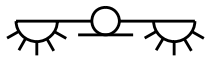

RAILROAD BEACON



DOWN GUY



GUY POLE



OAK TREE



PALM TREE

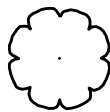

OTHER TREE

LOS ANGELES COUNTY PUBLIC WORKS

SYMBOLS

SHEET 3 OF 3

APPENDIX C

NOTE: THE FOLLOWING NOTES ARE TYPICAL NOTES USED FOR A TRAFFIC SIGNAL PROJECT. A DESIGNER/ENGINEER SHOULD ONLY CHOOSE THE APPROPRIATE NOTES THAT CORRESPOND TO THE PROJECT. BE MINDFUL NOT TO INCLUDE NOTES THAT CONFLICT WITH THE SPECIAL PROVISIONS.

TYPICAL GENERAL NOTES

FOR COUNTY ADMINISTERED PROJECTS





TRAFFIC SIGNAL PLANS:

1. REFER TO THE STANDARD SPECIFICATIONS FOR PUBLIC WORKS CONSTRUCTION 2018 EDITION, THE SPECIAL PROVISIONS, AND THE REFERENCED STANDARD PLANS FOR ADDITIONAL REQUIREMENTS NOT SHOWN ON THE PLANS.

-OR-

TRAFFIC SIGNAL, LIGHTING, STRIPING AND MARKINGS SHALL CONFORM TO THE STATE OF CALIFORNIA DEPARTMENT OF TRANSPORTATION STANDARD SPECIFICATIONS - SECTION 86, 2010 EDITION, AND STANDARD PLANS, 2010 EDITION, UNLESS OTHERWISE NOTED ON THE PLAN OR SPECIAL PROVISIONS.

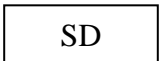
2. THE GPS UNIVERSAL TIME BASE UNIT ANTENNA SHALL BE LOCATED ON THE STREET SIDE OF THE TOP OF THE CONTROLLER CABINET.
3. ALL WIRING SHALL BE MARKED (TAGGED) WITHIN THE CONTROLLER CABINET FOR PHASE IDENTIFICATION.
4. ALL SIGNAL EQUIPMENT SHALL BE WIRED IN ACCORDANCE WITH THE PROPOSED OR EXISTING SIGNAL PHASE DIAGRAM.
5. (XXXX) OR (X-X-XX FOR NEMA CONTROLLERS) INDICATES LOOP AND/OR VIDEO DETECTION ZONE ASSIGNMENT IN THE CONTROLLER CABINET. EACH LOOP ASSIGNMENT SHALL HAVE A SEPARATE LEAD-IN CABLE TO THE CONTROLLER.
6. ALL LOOPS SHALL BE ROUND (6' DIAMETER), UNLESS OTHERWISE NOTED.
7. ALL LOOPS SHALL BE CENTERED IN THE MIDDLE OF THE LANE AND FRONT LOOPS SHALL BE PLACED BEHIND THE EDGE OF THE CROSSWALK OR LIMIT LINE, UNLESS OTHERWISE NOTED.

8. ALL DETECTION ZONES SHALL BE CENTERED IN THE MIDDLE OF THE LANE AND FRONT DETECTION ZONES SHALL BE PLACED BEHIND THE EDGE OF THE CROSSWALK OR LIMIT LINE, UNLESS OTHERWISE NOTED.
9. DETECTORS AND/OR VIDEO DETECTION ZONES SHALL BE WIRED/RE-CONFIGURED PER DETECTOR ASSIGNMENTS SHOWN ON THIS PLAN.
10.  INDICATES BICYCLE LOOP DETECTOR.
11.  INDICATES PROPOSED VIDEO DETECTION ZONE.
12.  INDICATES PROPOSED RADAR SENSING ZONE.
13.  INDICATES SYSTEM DETECTION ZONE.
14.  INDICATES VIDEO DETECTION/RADAR CAMERA.
15. REMOVAL OR RELOCATION OF WIRELESS RADIO EQUIPMENT AND ANTENNA WILL BE DONE BY THE AGENCY. CONTRACTOR SHALL CONTACT THE SIGNAL SHOP AT (626) 458-1700 TEN (10) WORKING DAYS IN ADVANCE FOR COORDINATION.
16. CCTV CAMERA WILL BE RELOCATED BY THE AGENCY. CONTRACTOR SHALL CONTACT THE SIGNAL SHOP AT (626) 458-1700 TEN (10) WORKING DAYS IN ADVANCE FOR COORDINATION.
17. SIGNAL, LIGHTING, AND ELECTRICAL SYSTEMS SHALL CONFORM TO THE CITY OF _____ SPECIFICATIONS. SEE SPECIAL PROVISIONS.
18. POLE LOCATIONS SHOWN HEREON ARE APPROXIMATE. PRECISE LOCATIONS SHALL BE ESTABLISHED IN THE FIELD AND VERIFIED BY THE PROJECT ENGINEER.
19. ALL NEW SIGNAL POLES WITH PEDESTRIAN PUSH BUTTONS SHALL BE INSTALLED NO FURTHER THAN 5 FEET FROM THE BACK OF CROSSWALK OR LIMIT LINE UNLESS OTHERWISE NOTED.
20. IT IS THE RESPONSIBILITY OF THE CONTRACTOR TO NOTIFY MR.(MS.) _____ OF <INSERT SERVICE PROVIDER NAME> AT _____ FOR ELECTRICAL SERVICE CONNECTION THIRTY (30) WORKING DAYS IN ADVANCE.
21. IT IS THE RESPONSIBILITY OF THE CONTRACTOR TO NOTIFY MR.(MS.) _____ OF <INSERT SERVICE PROVIDER NAME> AT _____ FOR THE REMOVAL / RELOCATION OF EXISTING STREET LIGHTS.

22. SERVICE POINT WILL BE DESIGNATED BY THE UTILITY COMPANY. THE CONTRACTOR SHALL INSTALL CONDUIT AND CONDUCTORS TO THE DESIGNATED POLE AND INSTALL TYPE _____ SERVICE AT THE DESIGNATED LOCATION.
23. ALL CONFLICTING LINES AND MARKINGS [THERMOPLASTIC] SHALL BE REMOVED BY GRINDING. ALL CONFLICTING LINES AND MARKINGS [PAINT] SHALL BE REMOVED BY WET SANDBLASTING, AND INCLUDES REMOVAL OF RAISED PAVEMENT MARKERS.
24. PROPOSED CROSSWALK SHALL BE 13' WIDE, MEASURED TO CENTER OF MARKINGS, UNLESS OTHERWISE NOTED.
25. ALL SIGNING SHOWN HEREON SHALL BE INSTALLED, RELOCATED, OR REMOVED BY THE AGENCY, UNLESS OTHERWISE NOTED.
26. CONTACT LOS ANGELES COUNTY DEPARTMENT OF PUBLIC WORKS, TRAFFIC AND LIGHTING DIVISION, TRAFFIC SYSTEMS SECTION AT (626) 300-4709 ONE MONTH IN ADVANCE OF SIGNAL CONSTRUCTION TO COORDINATE SIGNAL TIMING AND IMPLEMENTATION.

SIGNING AND STRIPING PLANS: (WHEN APPLICABLE)

1. ALL TRAFFIC LINES AND PAVEMENT MARKINGS SHOWN SHALL BE INSTALLED WITH (TAPE, TWO-COAT PAINT, OR THERMOPLASTIC) BY THE CONTRACTOR (OR AGENCY), UNLESS OTHERWISE NOTED.
2. ALL CONFLICTING LINES AND MARKINGS [THERMOPLASTIC] SHALL BE REMOVED BY GRINDING. ALL CONFLICTING LINES AND MARKINGS [PAINT] SHALL BE REMOVED BY WET SANDBLASTING, AND INCLUDES REMOVAL OF RAISED PAVEMENT MARKERS.
3. ALL TURN ARROW MARKINGS SHALL BE TYPE IV (L OR R) UNLESS OTHERWISE NOTED.
4. ALL LANE STRIPING AT INTERSECTION APPROACHES WITHOUT CROSSWALKS OR LIMIT LINES SHALL END 10 FEET FROM THE EXTENSION OF THE INTERSECTING CURB LINE.
5. ALL LANE LINES AT INTERSECTION APPROACHES AND DEPARTURES SHALL BEGIN AND END WITH 50 FEET OF 4-INCH SOLID WHITE LINE.
6. PROPOSED LIMIT LINE SHOULD BE INSTALLED AT A MINIMUM OF 4 FEET BEHIND THE EXISTING CURB EXTENSION OR EDGE OF TRAVEL WAY (NO EXISTING CURB RAMP). IN THE CASE OF AN INTERSECTION WITH A CURB RAMP, THE LIMIT LINE SHALL BE PLACED BEHIND THE RAMP'S LANDING AREA, BUT IN NO CASE GREATER THAN 30 FEET BACK.
7. ALL SIGNING SHOWN HEREON SHALL BE INSTALLED, RELOCATED, OR REMOVED BY THE CONTRACTOR, UNLESS OTHERWISE NOTED.

OR IF DONE BY THE AGENCY:

ALL SIGNING SHOWN HEREON SHALL BE INSTALLED, RELOCATED, OR REMOVED BY THE AGENCY, UNLESS OTHERWISE NOTED.

8. PROPOSED STRIPING BY THE AGENCY. (IF STRIPING DONE BY AGENCY).
9. SEE TRAFFIC SIGNAL PLAN FOR LOCATION OF CROSSWALKS AT SIGNALIZED INTERSECTIONS.
10. LOCATIONS OF PROPOSED SIGNS ARE SHOWN TO SCALE ON THE PLAN, UNLESS OTHERWISE NOTED.

NOTE: IN ADDITION TO THE TYPICAL GENERAL NOTES ALREADY LISTED, THE FOLLOWING ADDITIONAL NOTES APPLY TO PERMIT PROJECTS.

TYPICAL GENERAL NOTES

FOR PERMIT PROJECTS

TRAFFIC SIGNAL PLANS:

1. ALL MATERIALS AND EQUIPMENT SHALL BE FURNISHED AND INSTALLED BY THE CONTRACTOR, EXCEPT LACO-4E PROGRAM.
2. LACO-4E PROGRAM SHALL BE FURNISHED AND INSTALLED BY THE AGENCY.
3. THE GPS UNIVERSAL TIME BASE UNIT AND ANTENNA SHALL BE MOUNTED PER MANUFACTURER'S GUIDELINES. THE GPS UNIVERSAL TIME BASE UNIT ANTENNA SHALL BE LOCATED ON THE STREET SIDE OF THE TOP OF THE CONTROLLER CABINET.
4. (TWO-PAIR) DLC CABLE SHALL BE USED THROUGHOUT THE EXTENT OF THIS MODIFICATION UNLESS OTHERWISE NOTED.
5. THE CONTRACTOR SHALL ARRANGE FOR MANUFACTURER REPRESENTATIVE TO BE PRESENT DURING THE INSTALLATION OF THE VIDEO DETECTION SYSTEM AND CAMERA(S).
6. THE CONTRACTOR SHALL ARRANGE FOR MANUFACTURER REPRESENTATIVE TO BE PRESENT DURING THE INSTALLATION OF THE RADAR DETECTION SYSTEM AND RADAR UNIT(S).
7. ALL NEW POLES, CONDUIT, AND PULL BOXES SHALL BE INSTALLED OUTSIDE OF CURB RAMPS.
8. ALL NEW PULL BOXES SHALL BE NO. 6, UNLESS SHOWN OTHERWISE.
9. ALL NEW UNDERGROUND CONDUITS SHALL BE SCHEDULE 80 PVC, CONFORMING TO 700-3.5.4 OF THE STANDARD SPECIFICATIONS FOR PUBLIC WORKS CONSTRUCTION UNLESS OTHERWISE APPROVED BY THE ENGINEER.
10. ALL EXISTING CONDUITS SHALL BE REUSED UNLESS OTHERWISE NOTED OR APPROVED BY THE ENGINEER. ALL EXISTING INDIVIDUAL CONDUCTORS AFFECTED BY THE ADDITION OF NEW CONDUCTORS AND/OR DLC'S SHALL BE REMOVED AND REPLACED WITH MULTI-CONDUCTOR CABLES UNLESS OTHERWISE NOTED OR APPROVED BY THE ENGINEER.

11. IF EXISTING CONDUIT IS TO BE ABANDONED, REMOVE THE EXISTING CONDUCTORS.
12. THREE-CONDUCTOR CABLE (3CSC), FIVE-CONDUCTOR CABLE (5CSC), AND TWELVE-CONDUCTOR CABLE (12CSC) SHALL BE INSTALLED IN LIEU OF INDIVIDUAL CONDUCTORS. NO OTHER TRAFFIC SIGNAL (TS) MULTI CONDUCTOR CABLE WILL BE ACCEPTED UNLESS OTHERWISE APPROVED BY THE ENGINEER.

-OR-

- TWENTY-EIGHT-CONDUCTOR CABLE (28CSC) SHALL BE INSTALLED IN LIEU OF INDIVIDUAL CONDUCTORS. NO OTHER TRAFFIC SIGNAL (TS) MULTI CONDUCTOR CABLE WILL BE ACCEPTED UNLESS OTHERWISE APPROVED BY THE ENGINEER.
13. NEW VEHICLE HEADS SHALL BE 12" L.E.D. (LIGHT EMITTING DIODE) PER LOS ANGELES COUNTY DPW SPECIFICATIONS.
 14. TRAFFIC AND LIGHTING DIVISION SHALL PROVIDE A SKETCH INDICATING THE PROGRAMMED VISIBILITY HEAD ZONES.
 15. NEW PEDESTRIAN HEADS SHALL BE COUNTDOWN L.E.D. (LIGHT EMITTING DIODE).
 16. ALL NEW PEDESTRIAN PUSH BUTTONS SHALL BE INSTALLED IN CONFORMANCE WITH ADA REQUIREMENTS.
 17. CURB RAMPS TO BE CONSTRUCTED OR RECONSTRUCTED SHALL CONFORM TO THE CALTRANS STANDARD PLANS.
 18. ALL NEW CURB RAMP DETECTABLE WARNING SURFACES SHALL BE <INSERT COLOR> PER CITY OF _____ STANDARDS.
 19. THE CONTRACTOR SHALL CONTACT UNDERGROUND SERVICE ALERT (USA) BY DIALING 811 DURING USA'S BUSINESS HOURS ON OR BEFORE THE THIRD WORK DAY PRIOR TO ANY EXCAVATION. THE CONTRACTOR IS REQUIRED TO ASCERTAIN THE EXACT LOCATION OF THE UNDERGROUND FACILITIES PRIOR TO DOING WORK THAT MAY DAMAGE THE FACILITIES OR INTERFERE WITH THEIR SERVICE.
 20. ALL TRAFFIC LINES AND PAVEMENT MARKINGS SHALL BE INSTALLED WITH (TWO-COAT PAINT, TAPE, OR THERMOPLASTIC) BY THE CONTRACTOR (OR AGENCY), UNLESS OTHERWISE NOTED.
 21. EXISTING RAISED PAVEMENT MARKERS DAMAGED DURING REMOVAL SHALL BE REPLACED BY THE CONTRACTOR AT NO ADDITIONAL COST TO THE AGENCY.

APPENDIX D

TYPICAL CONSTRUCTION NOTES

1 REUSE EXISTING TYPE 332 CABINET COMPLETE WITH TYPE 170 ATC/HC-11 CONTROLLER, LACO-4E PROGRAM, (#) 2-CHANNEL ILD SENSOR UNITS, (#) PED ISOLATION MODULES, (#) SWITCH PACKS, (#) EV PREEMPTION MODULE(S), AND GPS UNIVERSAL TIME BASE UNIT AND ANTENNA.

-OR-

1 TYPE 170 ATC/HC-11 CONTROLLER, LACO-4E PROGRAM, (#) 2-CHANNEL ILD SENSOR UNIT(S), (#) SWITCH PACK(S).

2 REUSE EXISTING TYPE 332 CABINET COMPLETE WITH (#) 2-CHANNEL ILD SENSOR UNITS, (#) PED ISOLATION MODULES, AND (#) SWITCH PACKS. REMOVE EXISTING TYPE 170E CONTROLLER, LACO-1R WWV PROGRAM, AND RADIO CORRECTED TIME BASE UNIT.

-OR-

1 (#) 2-CHANNEL ILD SENSOR UNIT(S), (#) SWITCH PACK(S), AND GPS UNIVERSAL TIME BASE UNIT AND ANTENNA.

2 REUSE EXISTING TYPE 332 CABINET COMPLETE WITH TYPE 170 ATC/HC-11 CONTROLLER, LACO-4E PROGRAM, (#) 2-CHANNEL ILD SENSOR UNITS, (#) PED ISOLATION MODULES, (#) EV PREEMPTION MODULE(S), (#) SWITCH PACKS, AND BATTERY BACK-UP SYSTEM. REMOVE EXISTING RADIO CORRECTED TIME BASE UNIT.

-OR-

1 TYPE 332 CABINET ON NEW FOUNDATION COMPLETE WITH TYPE 170 ATC/HC-11 CONTROLLER, LACO-4E PROGRAM, (#) 2-CHANNEL ILD SENSOR UNITS, (#) PED ISOLATION MODULES, (#) SWITCH PACKS, AND GPS UNIVERSAL TIME BASE UNIT AND ANTENNA.

2 REMOVE EXISTING TYPE P CABINET AND TYPE ASC/2S-2100 CONTROLLER COMPLETE. REMOVE FOUNDATION.

-OR-

1 TYPE 332 CABINET ON NEW FOUNDATION COMPLETE WITH TYPE 170 ATC/HC-11 CONTROLLER, LACO-4E PROGRAM, (#) PED ISOLATION MODULES, (#) AC ISOLATION MODULE FOR RR PREEMPTION, (#) SWITCH PACKS, GPS UNIVERSAL TIME BASE UNIT AND ANTENNA, ITERIS VIDEO DETECTION SYSTEM COMPLETE WITH VANTAGE EDGE 2 PROCESSOR, ITERIS EDGE CONNECT MODULE, 17" LCD MONITOR AND RACK MOUNTED DRAWER OR AGENCY APPROVED EQUAL, AND ALL OTHER

EQUIPMENT NECESSARY FOR THE INTENDED OPERATION AS SHOWN ON THE PLAN. SEE SPECIAL PROVISIONS.

2 REMOVE EXISTING TYPE M CABINET COMPLETE WITH ASC-8000 CONTROLLER. REMOVE FOUNDATION.

-OR-

1 ECONOLITE AUTOSCOPE VIDEO DETECTION SYSTEM WITH RACK MOUNTED VIDEO PROCESSOR UNITS OR AGENCY APPROVED EQUAL, "D" CONNECTOR INTERFACE PANEL AND CABLE, (#) SWITCH PACKS, AND GPS UNIVERSAL TIME BASE UNIT AND ANTENNA.

2 REUSE EXISTING TYPE P CABINET COMPLETE WITH ASC/3S-2100 CONTROLLER, AND (#) SWITCH PACKS. REMOVE (#) ILD SENSOR UNIT.

3 RE-WIRE CONTROLLER CABINET.

4 LOOP(S) AS SHOWN.

5 PROTECT EXISTING LOOP WIRES.

6 SPLICE NEW LOOP(S) TO EXISTING DLC.

7 (#) 2-PAIR DLC ('S) TO CONTROLLER CABINET. LENGTH OF EACH DLC IS AS SHOWN ON PLAN.

8 VIDEO DETECTION CAMERA ON LUMINAIRE MAST ARM PER MANUFACTURER'S SPECIFICATIONS. SEE SPECIAL PROVISIONS AND GENERAL NOTE #___.

9 RADAR DETECTION UNIT PER MANUFACTURER'S SPECIFICATIONS. SEE SPECIAL PROVISIONS AND GENERAL NOTE #___.

10 ___" PVC CONDUIT. LENGTH IS AS SHOWN ON PLAN.

11 <INSERT #>-3" PVC CONDUIT. LENGTH IS AS SHOWN ON PLAN.

12 3" PVC CONDUIT PER SOUTHERN CALIFORNIA EDISON (SCE) SPECIFICATIONS. SEE GENERAL NOTE "#___".

13 NO. ___ PULL BOX.

14 INTERCEPT EXISTING CONDUIT.

15 REMOVE EXISTING PULL BOX.

16 RE-WIRE INTERSECTION.

- 17 ABANDON EXISTING LOOPS AS SHOWN.
- 18 3-12" LED VEHICLE HEAD (R, Y, G).
- 19 3-12" LED PROGRAMMED VISIBILITY HEAD (R, Y, G).
- 20 3-12" LED LOUVERED VEHICLE HEAD (R, Y, G).
- 21 LOUVERS ON YELLOW AND RED LENSES.
- 22 3-12" LED VEHICLE HEAD (R,Y,G) ON EXISTING STANDARD AS SHOWN. REMOVE EXISTING VEHICLE HEAD.
- 23 5-12" LED VEHICLE HEAD (R, Y, G, YA, GA) ON EXISTING STANDARD AS SHOWN. SEE DETAIL "X". REMOVE EXISTING VEHICLE HEAD.
- 24 REMOVE EXISTING VEHICLE HEAD. MODIFY SIGNAL MOUNTINGS AS NEEDED.
- 25 RELOCATE EXISTING VEHICLE HEAD AND/OR PEDESTRIAN HEAD AS SHOWN (SEE POLE SCHEDULE). MODIFY SIGNAL MOUNTINGS AS NEEDED.
- 26 ROTATE EXISTING VEHICLE HEAD AND CONNECT TO PHASE # AS INDICATED ON PLAN. MODIFY SIGNAL MOUNTINGS AS NEEDED.
- 27 LED PEDESTRIAN HEAD AS SHOWN.
- 28 RELOCATE EXISTING PEDESTRIAN HEAD AS SHOWN.
- 29 ROTATE EXISTING PEDESTRIAN HEAD AND CONNECT TO PHASE # AS INDICATED ON PLAN. MODIFY SIGNAL MOUNTINGS AS NEEDED.
- 30 PEDESTRIAN PUSH BUTTON ON EXISTING STANDARD. (SEE POLE SCHEDULE).
- 31 PEDESTRIAN PUSH BUTTON POST AND FOUNDATION. (SEE POLE SCHEDULE).
- 32 REMOVE PEDESTRIAN PUSH BUTTON AND PLATE HOLE TO A SMOOTH FINISH.
- 33 REMOVE EXISTING TYPE ___ STANDARD COMPLETE. REMOVE EXISTING FOUNDATION. (SEE POLE SCHEDULE).
- 34 REMOVE EXISTING TYPE ___ STANDARD NEAR HIGH VOLTAGE LINES COMPLETE. REMOVE EXISTING FOUNDATION. (SEE POLE SCHEDULE).

- 35 TYPE ____ STANDARD ON NEW FOUNDATION COMPLETE WITH EQUIPMENT AS SHOWN. (SEE POLE SCHEDULE).
- 36 CURB RAMP PER CASE ____ PER CALTRANS REVISED STANDARD PLAN RSP A88A.
- 37 SURFACE APPLIED DETECTABLE WARNING SURFACE PER CALTRANS REVISED STANDARD PLAN RSP A88A.
- 38 REMOVE EXISTING CURB RAMP AND REPLACE PAVEMENT IN KIND.
- 39 REMOVE RADIO CORRECTED TIME BASE UNIT ANTENNA.
- 40 RELOCATE EXISTING WIRELESS RADIO ANTENNA TO NEW STANDARD. SEE GENERAL NOTE # ____.
- 41 RELOCATE EXISTING VIDEO DETECTION CAMERA TO NEW STANDARD.
- 42 REUSE EXISTING WIRELESS RADIO EQUIPMENT.
- 43 RECONSTRUCT MEDIAN NOSE. SEE DETAIL _____. RESTRIPE CROSSWALK.
- 44 TYPE III-BF ANODIZED ALUMINUM UNDERGROUND SERVICE COMPLETE WITH FOUNDATION PER COUNTY OF LOS ANGELES DPW SPECIFICATIONS (SEE SPECIAL PROVISIONS).
- 45 TYPE III-BF ANODIZED ALUMINUM UNDERGROUND SERVICE CABINET PER CALTRANS STANDARD ES-2E COMPLETE WITH 1-120/240V, 2P MAIN CIRCUIT BREAKERS, 1-50A 120V, IP CIRCUIT BREAKERS FOR TRAFFIC SIGNALS (METERED) AND 2-30A, 120V IP CIRCUIT BREAKERS (UNMETERED) FOR HIGHWAY SAFETY LIGHTS. (SEE SPECIAL PROVISIONS).
- 45 REUSE EXISTING TYPE _____ UNDERGROUND SERVICE CABINET.
- 46 TYPE III-BF ANODIZED ALUMINUM UNDERGROUND SERVICE COMPLETE WITH FOUNDATION PER COUNTY OF LOS ANGELES DPW SPECIFICATIONS (SEE SPECIAL PROVISIONS).
- 47 REMOVE EXISTING SERVICE METER MOUNTED ON S.P. # (SERVICE POLE NUMBER. CALL OUT SERVICE QUADRANT, IF KNOWN OR IF NEW SERVICE IS TO BE INSTALLED OR IF MODIFYING THE EXISTING SERVICE).
- 48 STREET LIGHTING PULL BOX WITHOUT BALLAST. REMOVE BALLAST.

- 49 CURB RAMP WITH DETECTABLE WARNING SURFACE PER CALTRANS REVISED STANDARD PLAN RSP A88A CASE _____. (SEE SPECIAL PROVISIONS).
- 50 4" P.C.C. WALK OR 2" A.C. WALK (APPROXIMATE AREA INDICATED IN SQUARE FEET AND THIS AREA SHOWN HACHURED ON PLAN).
- 51 REMOVE; RELOCATE; REORIENT; REMOUNT; ABANDON; ADD BACK PLATE; REUSE; DISCONNECT.
- 52 CROWN RAISING, TREE (____"-____" DIAMETER). (SEE SPECIAL PROVISIONS).
- 53 SIGN(S) ON EXISTING STANDARD AS SHOWN.
- 54 SIGN(S) ON NEW POST AS SHOWN.
- 55 SIGN(S) AS SHOWN.
- 56 REMOVE EXISTING SIGN(S) AS SHOWN.
- 57 RELOCATE EXISTING SIGN(S) AS SHOWN.
- 58 RELOCATE EXISTING STREET NAME SIGN. (SEE POLE SCHEDULE).
- 59 ____" SOLID WHITE LINE. LENGTH IS AS SHOWN ON PLAN.
- 60 DETAIL _____. LENGTH IS AS SHOWN ON PLAN.
- 61 ____" CROSSWALK.
- 62 TYPE ____ ARROW PER CALTRANS STANDARD PLAN.
- 63 TYPE ____ PAVEMENT MARKING.
- 64 <INSERT COLOR> CURB MARKING. LENGTH IS AS SHOWN ON PLAN.
- 65 ____" WHITE DIAGONAL LINES.
- 66 12" YELLOW CROSSWALK.
- 67 REMOVE CONFLICTING STRIPING, INCLUDES REMOVAL OF RAISED PAVEMENT MARKERS.
- 68 REMOVE CONFLICTING PAVEMENT MARKING.
- 69 REMOVE EXISTING <INSERT COLOR> CURB MARKING.

APPENDIX E

County Traffic Signal Signature Blocks

NEW TRAFFIC SIGNAL

Original Traffic Signal Plan is Created.

1

SUBMITTED:	CIVIL ENGINEER NO. CXXXXX
BY: <u>Associate Civil Engineer</u>	DATE: _____
RECOMMENDED:	
BY: <u>Senior Civil Engineer</u>	DATE: _____
APPROVED: MARK PESTRELLA, DIRECTOR OF PUBLIC WORKS	
BY: <u>Division Head</u>	DATE: _____
ASSISTANT DEPUTY DIRECTOR	

Plan is done by **COUNTY STAFF**

Additional City Signature "Approved" Blocks May Be Required

2

REVIEWED:	
BY: <u>Associate Civil Engineer</u>	DATE: _____
RECOMMENDED:	
BY: <u>Senior Civil Engineer</u>	DATE: _____
APPROVED: MARK PESTRELLA, DIRECTOR OF PUBLIC WORKS	
BY: <u>Division Head</u>	DATE: _____
ASSISTANT DEPUTY DIRECTOR	

Plan is done by a **CONSULTANT**

Additional City Signature "Approved" Blocks May Be Required

MODIFICATION TO AN EXISTING TRAFFIC SIGNAL

Proposed Work is Drawn on a New Traffic Signal Plan.

3

SUBMITTED:	
BY: <u>Associate Civil Engineer</u>	DATE: _____
RECOMMENDED:	
BY: <u>Senior Civil Engineer</u>	DATE: _____
APPROVED: MARK PESTRELLA, DIRECTOR OF PUBLIC WORKS	
BY: <u>Division Head</u>	DATE: _____
ASSISTANT DEPUTY DIRECTOR	

Plan is done by **COUNTY STAFF**

100% COUNTY Jurisdiction

4

REVIEWED:	
BY: <u>Associate Civil Engineer</u>	DATE: _____
RECOMMENDED:	
BY: <u>Senior Civil Engineer</u>	DATE: _____
APPROVED: MARK PESTRELLA, DIRECTOR OF PUBLIC WORKS	
BY: <u>Division Head</u>	DATE: _____
ASSISTANT DEPUTY DIRECTOR	

Plan is done by a **CONSULTANT**

100% COUNTY Jurisdiction

APPENDIX E

County Traffic Signal Signature Blocks (Continued)

MODIFICATION TO AN EXISTING TRAFFIC SIGNAL (CONTINUED)

Proposed Work is Drawn on a New Traffic Signal Plan.

5

SUBMITTED: COUNTY OF LOS ANGELES
BY: <u>Associate Civil Engineer</u> DATE: _____
RECOMMENDED: COUNTY OF LOS ANGELES
BY: <u>Senior Civil Engineer</u> DATE: _____
APPROVED: CITY OF EL SEGUNDO
BY: <u>City Signature</u> DATE: _____
PROJECT ID NO. TSMXXXXXXX PCA NO. XXXXXXXX

Plan is done by **COUNTY STAFF**
100% CITY Jurisdiction

6

SUBMITTED: COUNTY OF LOS ANGELES
BY: <u>Associate Civil Engineer</u> DATE: _____
RECOMMENDED: COUNTY OF LOS ANGELES
BY: <u>Senior Civil Engineer</u> DATE: _____
APPROVED: MARK PESTRELLA, DIRECTOR OF PUBLIC WORKS
BY: <u>Division Head</u> DATE: _____ ASSISTANT DEPUTY DIRECTOR
APPROVED: CITY OF HAWTHORNE
BY: <u>City Signature</u> DATE: _____
PROJECT ID NO. TSMXXXXXXX PCA NO. XXXXXXXX

MAJOR Work is Proposed*

Plan is done by **COUNTY STAFF**
COUNTY has a percent of Jurisdiction

Additional City Signature "Approved" Blocks May Be Required

*NOTE: If only minor work is being done (signing, vehicle heads, loops, conduit/pull boxes), use signature block 6a.

6a

SUBMITTED: COUNTY OF LOS ANGELES
BY: <u>Associate Civil Engineer</u> DATE: _____
APPROVED: COUNTY OF LOS ANGELES
BY: <u>Senior Civil Engineer</u> DATE: _____
APPROVED: CITY OF HAWTHORNE
BY: <u>City Signature</u> DATE: _____
PROJECT ID NO. TSMXXXXXXX PCA NO. XXXXXXXX

MINOR Work is Proposed*

Plan is done by **COUNTY STAFF**
COUNTY has a percent of Jurisdiction

Additional City Signature "Approved" Blocks May Be Required

*NOTE: Signing, vehicle heads, loops, and conduit/pull boxes. For major work, use signature block 6.

APPENDIX E

County Traffic Signal Signature Blocks (Continued)

MODIFICATION TO AN EXISTING TRAFFIC SIGNAL (CONTINUED)

Proposed Work is Drawn on a New Traffic Signal Plan.

7

REVIEWED: COUNTY OF LOS ANGELES
BY: <u>Associate Civil Engineer</u> DATE: _____
RECOMMENDED: COUNTY OF LOS ANGELES
BY: <u>Senior Civil Engineer</u> DATE: _____
APPROVED: MARK PESTRELLA, DIRECTOR OF PUBLIC WORKS
BY: <u>Division Head</u> DATE: _____ ASSISTANT DEPUTY DIRECTOR
APPROVED: CITY OF LAWDALE
BY: <u>City Signature</u> DATE: _____
PROJECT ID NO. TSMXXXXXXX PCA NO. XXXXXXXX

MAJOR Work is Proposed*

Plan is done by a
CONSULTANT/CITY
COUNTY has a percent of Jurisdiction

Additional City Signature "Approved" Blocks May Be Required

***NOTE:** If only minor work is being done (signing, vehicle heads, loops, conduit/pull boxes), use signature block 7a.

7a

REVIEWED: COUNTY OF LOS ANGELES
BY: <u>Associate Civil Engineer</u> DATE: _____
APPROVED: COUNTY OF LOS ANGELES
BY: <u>Senior Civil Engineer</u> DATE: _____
APPROVED: CITY OF CALABASAS
BY: <u>City Signature</u> DATE: _____
PROJECT ID NO. TSMXXXXXXX PCA NO. XXXXXXXX

MINOR Work is Proposed*

Plan is done by a
CONSULTANT/CITY
COUNTY has a percent of Jurisdiction

Additional City Signature "Approved" Blocks May Be Required

***NOTE:** Signing, vehicle heads, loops, and conduit/pull boxes. For major work, use signature block 7.

8

REVIEWED: COUNTY OF LOS ANGELES
BY: <u>Associate Civil Engineer</u> DATE: _____
APPROVED: CITY OF INDUSTRY
BY: <u>City Signature</u> DATE: _____
PROJECT ID NO. TSMXXXXXXX PCA NO. XXXXXXXX

Plan is done by a
CONSULTANT/CITY
100% CITY Jurisdiction

Additional City Signature "Approved" Blocks May Be Required

NOTE: All plans reviewed by the County, regardless of the requestor, shall be signed by the County, as shown.

APPENDIX E

County Traffic Signal Signature Blocks (Continued)

MODIFICATION TO AN EXISTING TRAFFIC SIGNAL *Clouding of Proposed Work on an Existing Traffic Signal Plan.*

9

COUNTY OF LOS ANGELES DEPARTMENT OF PUBLIC WORKS	
PLAN REVISION R-X	
SCALE: 1"=20"	DRAWN BY:
SUBMITTED:	
BY: <u>Associate Civil Engineer</u>	DATE: _____
APPROVED:	
BY: <u>Senior Civil Engineer</u>	DATE: _____
ALL WORK TO BE DONE BY THE CONTRACTOR IS SHOWN CLOUDED. ALL OTHER WORK SHALL BE EXCLUDED.	

Clouding is done by
COUNTY STAFF
100% COUNTY Jurisdiction

Additional City Signature "Approved" Blocks May Be Required

10

COUNTY OF LOS ANGELES DEPARTMENT OF PUBLIC WORKS	
PROJECT ID NO. TSMXXXXXXX PCA NO. XXXXXXXX	
SCALE: 1"=20"	DRAWN BY:
REVIEWED:	
BY: <u>Associate Civil Engineer</u>	DATE: _____
APPROVED:	
BY: <u>Senior Civil Engineer</u>	DATE: _____
ALL WORK TO BE DONE BY THE CONTRACTOR IS SHOWN CLOUDED. ALL OTHER WORK SHALL BE EXCLUDED.	

Clouding is done by a
CONSULTANT
100% COUNTY Jurisdiction

Consultant shall put their own signature block and stamp on the plan, which shall be clouded.

Additional City Signature "Approved" Blocks May Be Required

11

COUNTY OF LOS ANGELES DEPARTMENT OF PUBLIC WORKS	
PLAN REVISION R-X	
SCALE: 1"=20"	DRAWN BY:
SUBMITTED: COUNTY OF LOS ANGELES	
BY: <u>Associate Civil Engineer</u>	DATE: _____
RECOMMENDED: COUNTY OF LOS ANGELES	
BY: <u>Senior Civil Engineer</u>	DATE: _____
APPROVED: CITY OF COMPTON	
BY: <u>City Signature</u>	DATE: _____
ALL WORK TO BE DONE BY THE CONTRACTOR IS SHOWN CLOUDED. ALL OTHER WORK SHALL BE EXCLUDED.	

Clouding is done by
COUNTY STAFF
100% CITY Jurisdiction

APPENDIX E

County Traffic Signal Signature Blocks (Continued)

MODIFICATION TO AN EXISTING TRAFFIC SIGNAL (CONTINUED)

Clouding of Proposed Work on an Existing Traffic Signal Plan.

12

COUNTY OF LOS ANGELES DEPARTMENT OF PUBLIC WORKS	
PLAN REVISION R-X	
SCALE: 1"=20"	DRAWN BY:
SUBMITTED: COUNTY OF LOS ANGELES	
BY: Associate Civil Engineer	DATE: _____
APPROVED: COUNTY OF LOS ANGELES	
BY: Senior Civil Engineer	DATE: _____
APPROVED: CITY OF COMPTON	
BY: City Signature	DATE: _____
ALL WORK TO BE DONE BY THE CONTRACTOR IS SHOWN CLOUDED. ALL OTHER WORK SHALL BE EXCLUDED.	

Clouding is done by
COUNTY STAFF
COUNTY has a percent of Jurisdiction

Additional City Signature "Approved" Blocks May Be
Required

13

COUNTY OF LOS ANGELES DEPARTMENT OF PUBLIC WORKS	
PROJECT ID NO. TSMXXXXXXX PCA NO. XXXXXXXX	
SCALE: 1"=20"	DRAWN BY:
REVIEWED: COUNTY OF LOS ANGELES	
BY: Associate Civil Engineer	DATE: _____
APPROVED: COUNTY OF LOS ANGELES	
BY: Senior Civil Engineer	DATE: _____
APPROVED: CITY OF LAWDALE	
BY: City Signature	DATE: _____
ALL WORK TO BE DONE BY THE CONTRACTOR IS SHOWN CLOUDED. ALL OTHER WORK SHALL BE EXCLUDED.	

Clouding is done by a
CONSULTANT/CITY
COUNTY has a percent of Jurisdiction

Consultant shall put their own signature block
and stamp on the plan, which shall be clouded.

Additional City Signature "Approved" Blocks May Be
Required

14

COUNTY OF LOS ANGELES DEPARTMENT OF PUBLIC WORKS	
PROJECT ID NO. TSMXXXXXXX PCA NO. XXXXXXXX	
SCALE: 1"=20"	DRAWN BY:
REVIEWED: COUNTY OF LOS ANGELES	
BY: Associate Civil Engineer	DATE: _____
APPROVED: CITY OF WEST COVINA	
BY: City Signature	DATE: _____
ALL WORK TO BE DONE BY THE CONTRACTOR IS SHOWN CLOUDED. ALL OTHER WORK SHALL BE EXCLUDED.	

Clouding is done by a
CONSULTANT/CITY
100% CITY Jurisdiction

Additional City Signature "Approved" Blocks May Be
Required

Consultant shall put their own signature block
and stamp on the plan, which shall be clouded.

**NOTE: All plans reviewed by the County, regardless of
the requestor, shall be signed by the County, as shown.**

APPENDIX E

County Traffic Signal Signature Blocks (Continued)

MODIFICATION TO AN EXISTING TRAFFIC SIGNAL *Clouding of Proposed Work on an Existing Traffic Signal Plan.*

NOTE: The following signature blocks are for use by COUNTY STAFF ONLY

15

COUNTY OF LOS ANGELES DEPARTMENT OF PUBLIC WORKS	
EXTRAORDINARY MAINTENANCE	
SCALE: 1"=20"	DRAWN BY: _____
SUBMITTED: COUNTY OF LOS ANGELES	
BY: Associate Civil Engineer _____	DATE: _____
APPROVED: COUNTY OF LOS ANGELES	
BY: Senior Civil Engineer _____	DATE: _____

EXTRAORDINARY MAINTENANCE
Additional City Signature "Approved" Blocks May Be Required

16

COUNTY OF LOS ANGELES DEPARTMENT OF PUBLIC WORKS	
FORCE ACCOUNT	
SCALE: 1"=20"	DRAWN BY: _____
SUBMITTED: COUNTY OF LOS ANGELES	
BY: Associate Civil Engineer _____	DATE: _____
APPROVED: COUNTY OF LOS ANGELES	
BY: Senior Civil Engineer _____	DATE: _____

FORCE ACCOUNT
Additional City Signature "Approved" Blocks May Be Required

APPENDIX F

POLE SCHEDULE

NO.	POLE TYPE	SPEC YEAR	SIGNAL MOUNTING		LUMINAIRE		PED PUSH BUTTON		STREET NAME SIGN		POLE LOCATION						
			M.A. LENGTH	M.A.	POLE	PED	M.A. LENGTH	H.P.S. WATTS	NO.	PHASE	TYPE	LEGEND	A	B	C	D	E
①	26-4-100(N)	2010	45'(N)	MAS(N)	SV-2-TA(N)	SP-1-T(N)	15'(N)	250(N)*	1(N)	8	R.R.(N)	SIDE STREET	---	---	10'	---	4'
②	15TS(N)	2010	----	----	SV-1-T(N)	SP-1-T(N)	12'(N)	250(N)	1(N)	2	----	----	14'	---	---	---	----
③	26-4-70	----	40'	2-MAS	SV-1-T	SP-1-T	12'	250	1	2	I.I.	ARTERIAL AVENUE	---	---	17'	---	4'
④	1A	----	----	----	TV-2-T	SP-1-T	----	----	1	4	----	----	15'	---	---	---	----
⑤	26-4-100(N)▲	2010	45'(N)	2-MAS(N)	SV-2-TA / SV-1-T	SP-1-T(N)	15'(N)**	250(N)*	1(N)	4	R.R.(R)	SIDE STREET	---	---	8'	---	3'
⑥	1A	----	----	----	TV-1-T	SP-1-T	----	----	1	6	----	----	4.5'	---	---	---	----
⑦	24-3-70	----	35'	2-MAS	SV-1-T	SP-1-T	12'	250	1	6	I.I.	ARTERIAL AVENUE	---	---	EX.	---	----
⑧	1A	----	----	----	TV-1-T	SP-1-T	----	----	1	8	----	----	2'	---	---	---	----

ALL EQUIPMENT SHOWN IS EXISTING UNLESS OTHERWISE NOTED.

(N) - DENOTES NEW EQUIPMENT.

(R) - DENOTES RELOCATED EQUIPMENT.

I.I. - INDICATES INTERNALLY ILLUMINATED STREET NAME SIGN

R.R. - INDICATES RETRO-REFLECTIVE STREET NAME SIGN

ALL NEW SIGNAL POLES AND MAST ARMS SHALL BE PER CALTRANS STANDARD PLANS, 2010 EDITION.

ALL SIGNAL MOUNTINGS SHALL BE PER STANDARD PLANS FOR PUBLIC WORKS CONSTRUCTION 2012 EDITION.

* - LED EQUIVALENT HIGHWAY SAFETY LIGHT. SEE SPECIAL PROVISIONS.

** - HORIZONTAL LUMINAIRE MAST ARM.

▲ - NEAR HIGH VOLTAGE LINES.

APPENDIX G

ADDITIONAL PHOTOS

- CABINET LOCATION
- SERVICE LOCATION
- BATTERY BACKUP CABINET LOCATION
- FRONT OF CONTROLLER EQUIPMENT
- BACK OF CONTROLLER EQUIPMENT
- ANTENNA LOCATION
- RADIO LOCATION

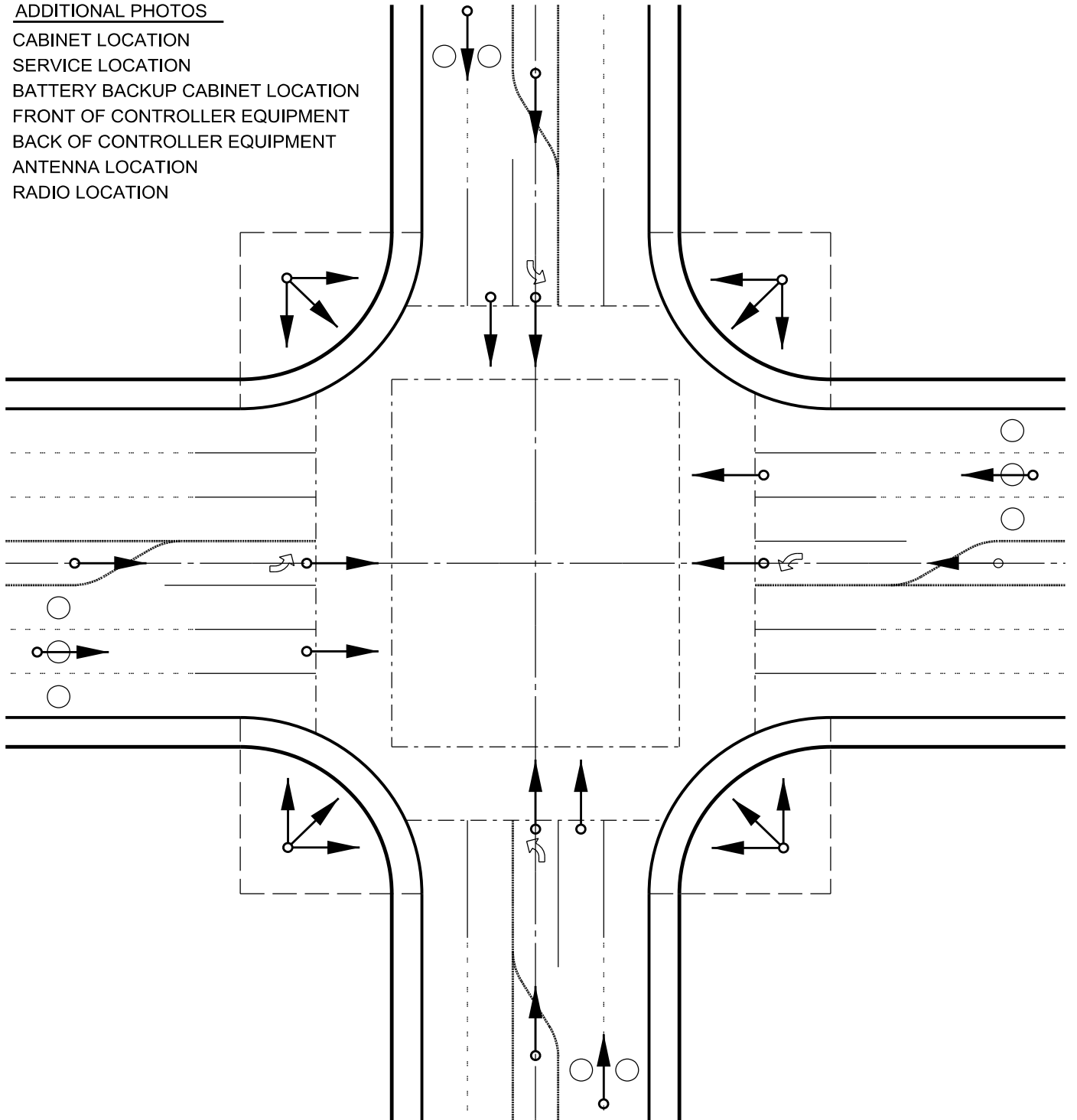

← ○ INDICATES PHOTO LOCATION
& DIRECTION OF PHOTO

APPENDIX H - SAMPLE UTILITY PLAN 1

- UTILITIES**
- SEWER: SANITATION DISTRICT OF LOS ANGELES COUNTY (SDLAC)
 - NATURAL GAS: SOUTHERN CALIFORNIA GAS COMPANY (SCGC)
TEXACO INC. (TEXACO)
 - OIL: GETTY OIL CO. (GETTY)
ATLANTIC RICHFIELD CO. (ARCO)
SHELL OIL CO. (SHELL)
 - TELEPHONE: AT&T CORP. (AT&T)
 - WATER: METROPOLITAN WATER DISTRICT (MWD)
 - POWER: SOUTHERN CALIFORNIA EDISON (SCE)

- SUBSTRUCTURE LEGEND**
- (A) 18" VCP SEWER (SDLAC) 4' ± W/O CL
 - (B) 16" STL GAS (SCGC) 19' ± E/O CL (ABAND.)
 - (C) 10" STL GAS (TEXACO) 20' ± E/O CL (ABAND.)
 - (D) 6" STL OIL (GETTY) 22' ± W/O CL
 - (E) 8" STL GAS (SCGC) 10' ± E/O CL
 - (F) 2-3" STL OIL (GETTY) 12' ± E/O CL (ABAND.)
 - (G) 10" STL OIL (ARCO) 22' ± E/O CL (ABAND.)
 - (H) 8" STL GAS (TEXACO) 22' ± E/O CL (ABAND.)
 - (I) 4" STL OIL (ARCO) 27' ± E/O CL
 - (J) 6" STL OIL (SHELL) 34' ± E/O CL
 - (K) 6" STL OIL (ARCO) 22' ± W/O CL
 - (L) 6" STL OIL (ARCO) 29' ± E/O CL (ABAND.)
 - (M) 8-4" PVC TEL DUCT (AT&T) 34' ± N/O CL
 - (N) 6" STL OIL (GETTY) 20' ± W/O CL
 - (O) 8" STL OIL (GETTY) 19' ± W/O CL
 - (P) 16" CI WATER (MWD) 6' ± E/O CL
 - (Q) 2-5" PVC ELEC (SCE) 39' ± E/O CL
 - (R) 4" STL GAS (SCGC) 16' ± E/O CL (ABAND.)
 - (S) 4" CI WATER (MWD) 27' ± E/O CL (ABAND.)
 - (T) 2-3" STL OIL (GETTY) 32' ± E/O CL
 - (U) 6" STL OIL (SHELL) 35' ± E/O CL
 - (V) 8" STL GAS (SCGC) 14' ± E/O CL
 - (W) 8" STL GAS (TEXACO) 26' ± E/O CL
 - (X) 8" STL OIL (GETTY) 31' ± W/O CL
 - (Y) 6-5" PVC ELEC (SCE) 30' ± W/O CL
 - (Z) 3" STL GAS (TEXACO) 27' ± W/O CL
 - (AA) 16" CI WATER (MWD) 23' ± W/O CL

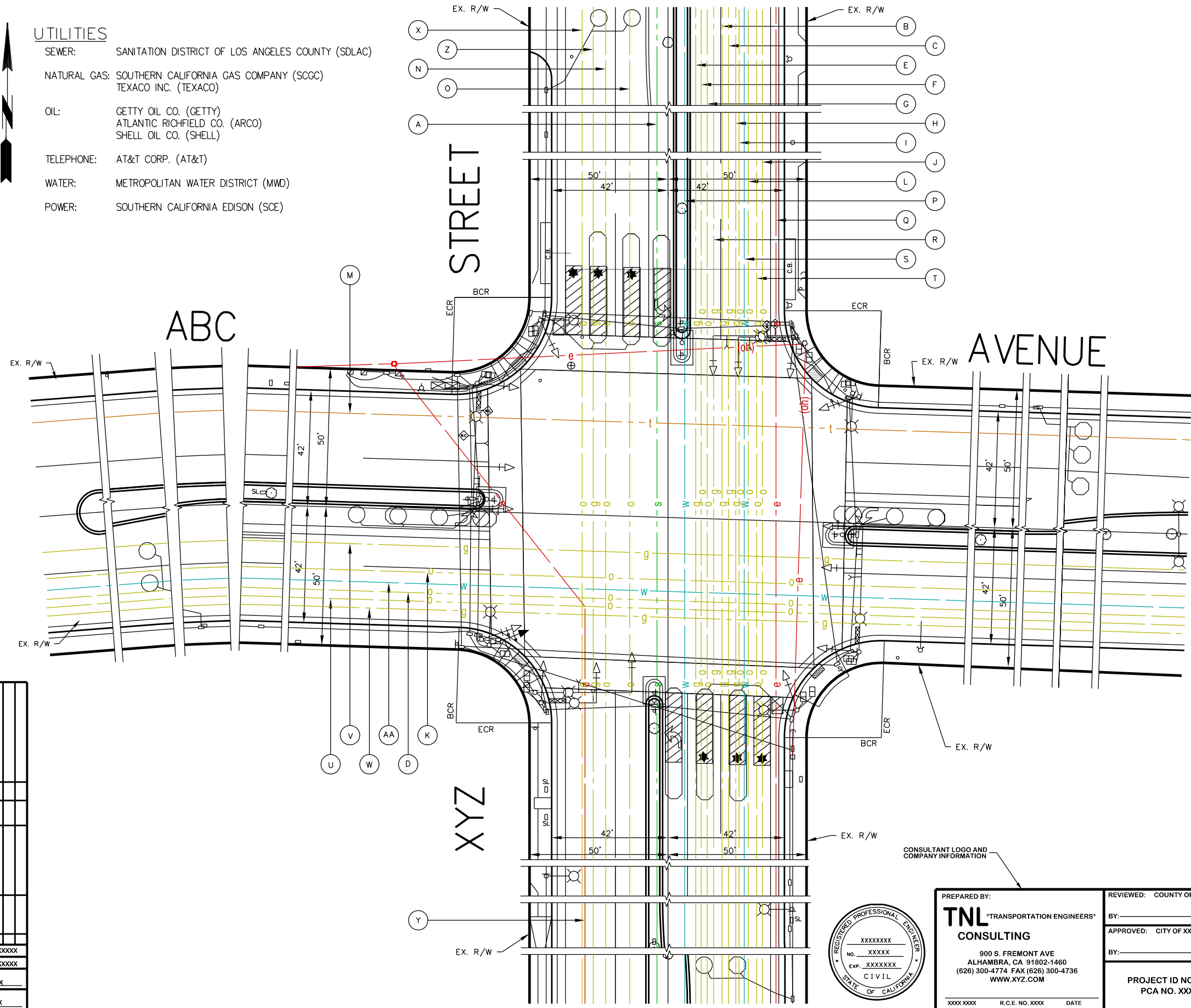

#	REVISIONS	DATE	BY
1	XXXXXXXXXX		
2	XXXXXXXXXX		
3	XXXXXXXXXX		
4	XXXXXXXXXX		
5	XXXXXXXXXX		
6	XXXXXXXXXX		
7	XXXXXXXXXX		
8	XXXXXXXXXX		
9	XXXXXXXXXX		
10	XXXXXXXXXX		



PREPARED BY:
TNL TRANSPORTATION ENGINEERS
 CONSULTING
 900 S. FREMONT AVE
 ALHAMBRA, CA 91802-1460
 (626) 300-4774 FAX (626) 300-4736
 WWW.XYZ.COM

REVIEWED: COUNTY OF LOS ANGELES
 BY: _____ DATE: _____
 APPROVED: CITY OF XXXXXXXX
 BY: _____ DATE: _____
 PROJECT ID NO. TSMXXXXXX
 PCA NO. XXXXXXXX

100% CITY OF XXXXXXXX
 COUNTY OF LOS ANGELES
 DEPARTMENT OF PUBLIC WORKS
 TRAFFIC AND LIGHTING DIVISION
**UTILITY PLAN
 ABC AVENUE
 AT
 XYZ STREET**
 1/S X OF X SHT X OF X SCALE: 1" = 40' T.S. XXXX

APPENDIX H - SAMPLE CLOUDING T.S. PLAN

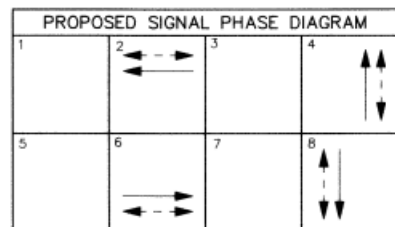
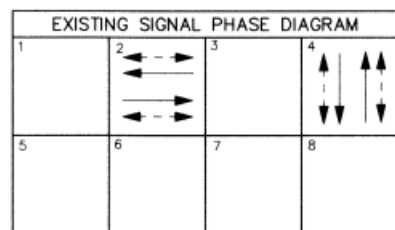

OPERATION:
 #2 AND #6 ON VEHICLE RECALL
 #2 AND #6 ON PEDESTRIAN RECALL/REST IN WALK
 #4 AND #8 ON NON-LOCK AND DOUBLE ENTRY



GENERAL NOTES CONTINUED:

15. REMOVAL OR RELOCATION OF WIRELESS RADIO EQUIPMENT AND ANTENNA WILL BE DONE BY THE AGENCY. CONTRACTOR SHALL CONTACT THE SIGNAL SHOP AT (626) 458-1700 TEN (10) WORKING DAYS IN ADVANCE FOR COORDINATION.

GENERAL NOTES

- TRAFFIC SIGNAL AND LIGHTING SHALL CONFORM TO THE LOS ANGELES COUNTY STANDARDS WHICH INCLUDE THE STANDARD PLANS FOR PUBLIC WORKS CONSTRUCTION, 2012 EDITION, STANDARD SPECIFICATIONS FOR PUBLIC WORKS CONSTRUCTION (GREEN BOOK), 2018 EDITION, AND THE LOS ANGELES COUNTY DEPARTMENT OF PUBLIC WORKS TRAFFIC SIGNAL CONTROL EQUIPMENT SPECIFICATIONS, LATEST EDITION, UNLESS OTHERWISE NOTED ON THE PLAN OR IN THE SPECIAL PROVISIONS.
- ALL MATERIALS AND EQUIPMENT SHALL BE FURNISHED AND INSTALLED BY THE CONTRACTOR.
- ALL WIRING SHALL BE MARKED (TAGGED) WITHIN THE CONTROLLER CABINET FOR PHASE IDENTIFICATION.
- ALL SIGNAL EQUIPMENT SHALL BE WIRED IN ACCORDANCE WITH THE PROPOSED SIGNAL PHASE DIAGRAM.
- (XXXX) INDICATES LOOP ASSIGNMENT IN THE CONTROLLER CABINET. EACH LOOP ASSIGNMENT SHALL HAVE A SEPARATE LEAD-IN CABLE TO THE CONTROLLER.
- ALL EXISTING CONDUITS SHALL BE REUSED UNLESS OTHERWISE NOTED OR APPROVED BY THE ENGINEER. ALL EXISTING INDIVIDUAL CONDUCTORS AFFECTED BY THE ADDITION OF NEW CONDUCTORS AND/OR DLC'S SHALL BE REMOVED AND REPLACED WITH MULTI-CONDUCTOR CABLES UNLESS OTHERWISE NOTED OR APPROVED BY THE ENGINEER.
- NEW VEHICLE HEADS SHALL BE 12" L.E.D. (LIGHT EMITTING DIODE) VEHICLE HEADS PER LOS ANGELES COUNTY DPW SPECIFICATIONS. (SEE SPECIAL PROVISIONS)
- ALL NEW UNDERGROUND CONDUIT SHALL BE SCHEDULE 80 PVC, UNLESS OTHERWISE APPROVED BY THE ENGINEER.
- FOR DISPOSITION OF SALVAGED MATERIALS, SEE SPECIAL PROVISIONS.
- LOOPS SHALL BE CENTERED IN THE LANE AND PLACED BEHIND THE EDGE OF THE CROSSWALK OR LIMIT LINE, UNLESS OTHERWISE NOTED.
- ALL LOOPS SHALL BE ROUND (6" DIAMETER), UNLESS OTHERWISE NOTED.
- ALL NEW PULL BOXES SHALL BE NO. 6 UNLESS OTHERWISE NOTED.
- THREE-CONDUCTOR CABLE (3 CSC), FIVE-CONDUCTOR CABLE (5 CSC), AND TWELVE-CONDUCTOR CABLE (12 CSC) SHALL BE INSTALLED IN LIEU OF INDIVIDUAL CONDUCTORS AND SHALL CONFORM TO SECTION 86-2.08D OF THE CALTRANS STANDARD SPECIFICATIONS FOR CONSTRUCTION OF LOCAL STREETS AND ROADS, (LATEST EDITION) UNLESS OTHERWISE SPECIFIED IN THE SPECIAL PROVISIONS. NO OTHER TRAFFIC SIGNAL (TS) MULTI-CONDUCTOR CABLE WILL BE ACCEPTED UNLESS OTHERWISE APPROVED BY THE ENGINEER.
- EXACT LOCATION OF ALL SHOWN UTILITIES IS THE RESPONSIBILITY OF THE CONTRACTOR TO VERIFY.

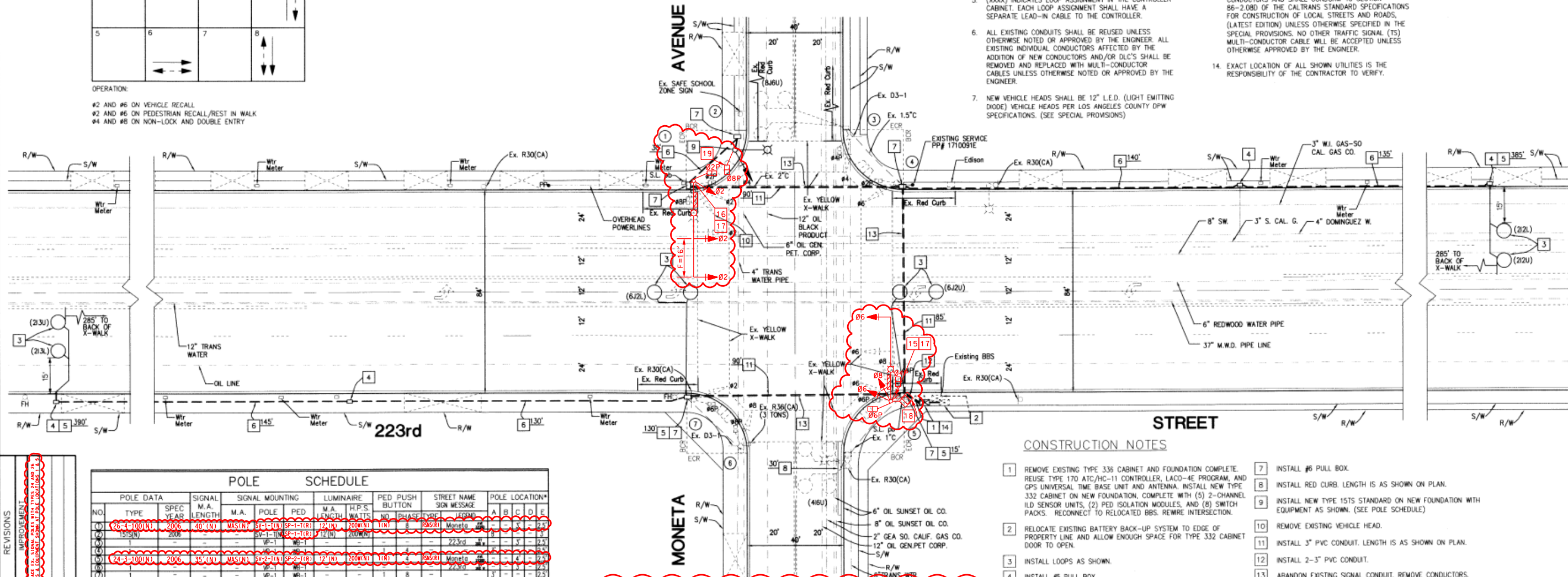

POLE DATA		SIGNAL		SIGNAL MOUNTING		LUMINAIRE		PED PUSH BUTTON		STREET NAME SIGN MESSAGE		POLE LOCATION*					
NO.	TYPE	SPEC YEAR	M.A. LENGTH	M.A.	POLE	PED	M.A. H.P.S.	NO.	PHASE	TYPE	HEIGHT	A	B	C	D	E	
(1)	26-1-100(N)	2005	40'(N)	MAS(N)	SV-1-(N)	SP-1-(R)	12'(N)	200(W)	1(T)	8	R30(R)	Moneta	223rd	1	1	1	1
(2)	26-1-100(N)	2005	40'(N)	MAS(N)	SV-1-(N)	SP-1-(R)	12'(N)	200(W)	1(T)	8	R30(R)	Moneta	223rd	1	1	1	1
(3)	26-1-100(N)	2005	40'(N)	MAS(N)	SV-1-(N)	SP-1-(R)	12'(N)	200(W)	1(T)	8	R30(R)	Moneta	223rd	1	1	1	1

NOTES: ALL EQUIPMENT EXISTING, UNLESS SHOWN OTHERWISE:
 (N) = NEW RSNS = REFLECTIVE STREET NAME SIGN
 (1) = NEW MOUNTING OF EXISTING SIGNAL HEAD
 (R) = DENOTES RELOCATED EQUIPMENT

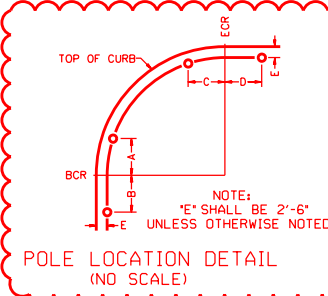

COUNTY OF LOS ANGELES DEPARTMENT OF PUBLIC WORKS

PLAN REVISION R-1

SCALE: 1" = 20" DRAWN BY: _____
 SUBMITTED: COUNTY OF LOS ANGELES
 BY: _____ DATE: _____
 RECOMMENDED: COUNTY OF LOS ANGELES
 BY: _____ DATE: _____
 APPROVED: CITY OF CARSON
 BY: _____ DATE: _____

ALL WORK TO BE DONE BY THE CONTRACTOR IS SHOWN CLOUDING. ALL OTHER WORK SHALL BE EXCLUDED.

CONSTRUCTION NOTES

- REMOVE EXISTING TYPE 336 CABINET AND FOUNDATION COMPLETE. REUSE TYPE 170 ATC/HC-11 CONTROLLER, LACO-4E PROGRAM, AND GPS UNIVERSAL TIME BASE UNIT AND ANTENNA. INSTALL NEW TYPE 332 CABINET ON NEW FOUNDATION. COMPLETE WITH (5) 2-CHANNEL I.D. SENSOR UNITS, (2) PED ISOLATION MODULES, AND (8) SWITCH PACKS. RECONNECT TO RELOCATED BBS. REWIRE INTERSECTION.
- RELOCATE EXISTING BATTERY BACK-UP SYSTEM TO EDGE OF PROPERTY LINE AND ALLOW ENOUGH SPACE FOR TYPE 332 CABINET DOOR TO OPEN.
- INSTALL LOOPS AS SHOWN.
- INSTALL #5 PULL BOX.
- INSTALL NEW (1) 2-PAIR DLC TO CONTROLLER CABINET. LENGTH OF EACH DLC IS AS SHOWN ON PLAN.
- INSTALL 2" PVC CONDUIT. LENGTH IS AS SHOWN ON PLAN.
- TYPE 24 STANDARD AND FOUNDATION WITH EQUIPMENT AS SHOWN. (SEE POLE SCHEDULE)
- TYPE 26 STANDARD AND FOUNDATION WITH EQUIPMENT AS SHOWN. (SEE POLE SCHEDULE)
- REMOVE EXISTING STANDARD AND FOUNDATION COMPLETE. RELOCATE EXISTING STREET NAME SIGN AND PEDESTRIAN HEADS.
- INSTALL #6 PULL BOX.
- INSTALL RED CURB. LENGTH IS AS SHOWN ON PLAN.
- INSTALL NEW TYPE 15TS STANDARD ON NEW FOUNDATION WITH EQUIPMENT AS SHOWN. (SEE POLE SCHEDULE)
- REMOVE EXISTING VEHICLE HEAD.
- INSTALL 3" PVC CONDUIT. LENGTH IS AS SHOWN ON PLAN.
- INSTALL 2-3" PVC CONDUIT.
- ABANDON EXISTING SIGNAL CONDUIT. REMOVE CONDUCTORS.
- REUSE EXISTING WIRELESS RADIO EQUIPMENT.

REVISIONS	DATE	BY	DESCRIPTION
R-1	12/13/10	MOHAMMAD R. HEIAT	REVISION R-1

Underground Service Alert
DIG ALERT
 Call: TOLL FREE 1-800-227-2600

THIS PLAN ACCURATE FOR PROPOSED WORK ONLY.

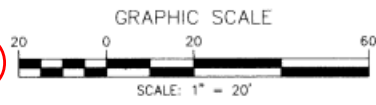

100% CITY OF CARSON

COUNTY OF LOS ANGELES DEPARTMENT OF PUBLIC WORKS TRAFFIC AND LIGHTING DIVISION

TRAFFIC SIGNAL PLAN
223RD STREET AT MONETA AVENUE

PLANS PREPARED BY:
VA Consulting, Inc.
 ENGINEERS PLANNERS SURVEYORS
 6400 OAK CANYON, SUITE 150 IRVINE, CA 92618 (949) 474-1400

UNDER THE SUPERVISION OF:
 MOHAMMAD R. HEIAT R.C.E. 45776 DATE: 12/13/10

REVIEWED: COUNTY OF LOS ANGELES
 APPROVED BY: *Joy Krajci* DATE: 12-8-10
 APPROVED BY: *M. Heiat* DATE: 12/13/10

PROJECT ID TSM0010064
 PROJECT NO. X7401036